

# Hold and go! Self-Centering Vices

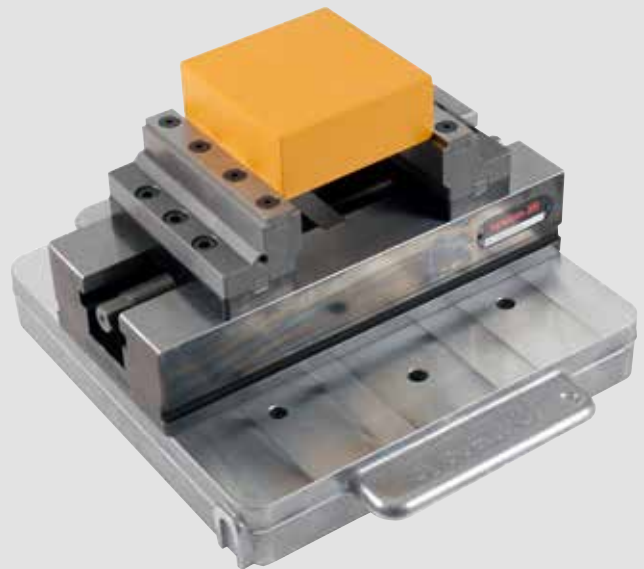

# Self-Centering Vices and accessories

Mounted on pallets or reference elements, System 3R's self-centering machine vices offer many clear advantages:

- High cutting performance, centering and repeat accuracy
- High clamping and holding force
- Stable, durable, one-piece construction
- Optimum accessibility
- Centric spindle bearing
- Centric clamping
- Easy cleaning.

System 3R is your unique partner to guarantee accuracy and repeatability of your clamping solution. Easy to order. Available immediately!

- Available on Dynafix pallets, Marco Magnum reference elements and Macro reference elements
- The centering vices are mounted with a symmetry accuracy of 0.02 mm to the reference cross of the pallet, respective the reference elements.
- The basic configuration of the vices is without clamping inserts respective clamping jaws. You can choose in between grip inserts/grip jaws for raw parts clamping inserts/clamping jaws for 2nd /3rd side operations.

## Centering vice, Dynafix, 3R-778-CV

Centering vice on Dynafix pallet. Choose between different inserts (not included).

- Vice length 280 mm
- Jaws width 125 mm
- Clamping length 186/246 mm
- Clamping force 50,000 N
- Weight 22.8 kg

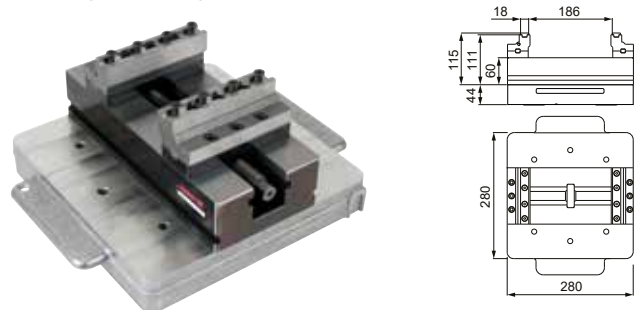

## Centering vice, MacroMagnum, 3R-688-CV

Centering vice on MacroMagnum reference element. Choose between different inserts (not included).

- Vice length 160 mm
- Jaws width 60 mm
- Clamping length 49/93 mm
- Clamping force 30,000 N
- Weight 6.8 kg

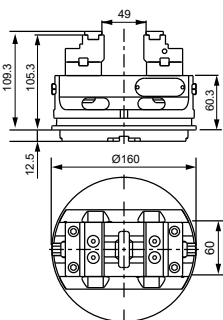

## Centering vice, Macro, 3R-658-CV

Centering vice on Macro reference element. Choose between different jaws (not included).

- Vice length 80 mm
- Jaws width 36 mm
- Clamping length 30/78 mm
- Clamping force 16,000 N
- Weight 0.9 kg

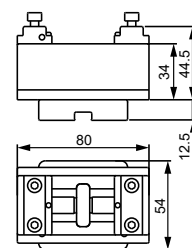

## Centering vices and accessories

### Pair of clamping inserts, Dynafix, 3R-778-J4

Clamping inserts 125 mm. Rough carbide coating. Fits on Centering vice, Dynafix, 3R-778-CV.

- Weight 0.15 kg

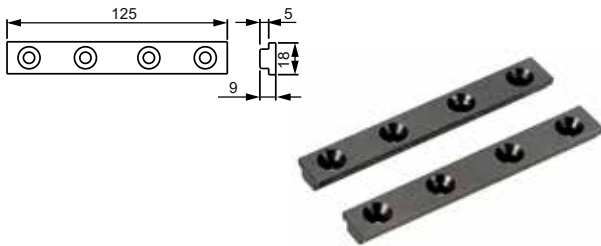

### Pair of grip inserts, Dynafix, 3R-778-J3

Grip inserts 125 mm. Fits on Centering vice, Dynafix, 3R-778-CV.

- Weight 0.15 kg

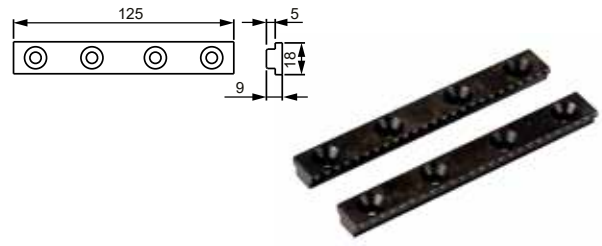

### Pair of clamping inserts, MacroMagnum, 3R-688-J4

Clamping inserts 60 mm. Rough carbide coating. Fits on Centering vice, MacroMagnum, 3R-688-CV.

- Weight 0.1 kg



### Pair of grip inserts, MacroMagnum, 3R-688-J3

Grip inserts 60 mm. Fits on Centering vice, MacroMagnum, 3R-688-CV.

- Weight 0.1 kg



### Pair of clamping jaws, Macro, 3R-658-J2

Clamping jaws 36 mm. Fits on Centering vice, Macro, 3R-658-CV.

- Weight 0.2 kg

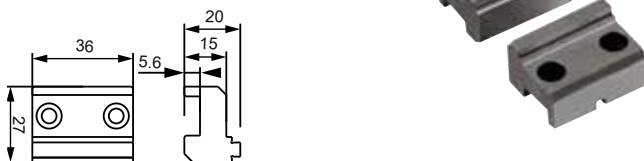

### Pair of grip jaws, Macro, 3R-658-J1

Grip jaws 36 mm. Fits on Centering vice, Macro, 3R-658-CV.

- Weight 0.2 kg

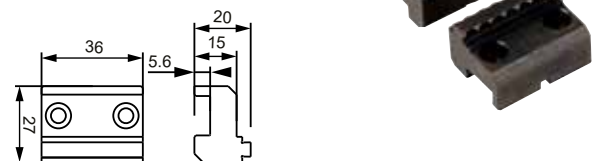

# Use our Customer Services to optimise your equipment uptime

System 3R's Customer Services department is uniquely positioned to help you maximise the availability, value, precision and productivity of your System 3R equipment. Our cost-effective, customer-centric and expert services put your success at the centre, ramp up your productivity and ensure predictable, uninterrupted uptime. System 3R's service engineers are your expert partners for a wide range of success-triggering services. For further details, contact your local System 3R dealer.

[www.system3r.com](http://www.system3r.com)