

Matrix

Measures to reduce the downtime of your machines are significantly more worthwhile than chasing seconds in the actual machining process. What matters is keeping machines running. This is when you need an interface that enables rapid set-up..

The Matrix system is just such an interface. While machines are working on one job, upcoming jobs are set up in parallel away from them. The set-up for each new job is then installed in the stationary machine in a matter of seconds. Important for long runs, but crucial for the profitability of short runs or one-off production.

System design has been optimised for metal-cutting machining and is ideal for work involving high machining forces. The drawbar's generous diameter means short distances between references and applied locking force. This gives maximum stability and accuracy. The inherent advantages of the Matrix system truly come into their own in tough machining applications.

ADVANTAGES

- Reduces set-up times.
- Ensures precision and quality.
- Has automatic air-blast cleaning of the references.
- Is sealed against dirt and swarf; withstands harsh work environments.
- Has enhanced clamping force force (turbo locking).
- Is suitable for automatic changing with System 3R's automation program.

As well as extreme accuracy, Matrix features low construction height, ultra-precise indexing and a drawbar with a through hole. The through hole allows high/long workpieces to be sunk into the chuck for stable/rigid mounting.

- Repetition accuracy:
 - Matrix 110 and Matrix 142 within 0.002 mm
 - Matrix 185, Matrix 220 and Matrix 260 within 0.003 mm.
- Fixed index positions 4x90°
- Required air pressure, pneumatic chuck 6 bars (± 1).
- Clamping force:
 - Matrix 110, 9,000 N
 - Matrix 142, 15,000 N
 - Matrix 185, 20,000 N
 - Matrix 220, 23,000 N
 - Matrix 260, 28,000 N
- Max. workpiece weight (manual loading):
 - Matrix 110, 50 kg
 - Matrix 142 and Matrix 185, 100 kg
 - Matrix 220 and Matrix 260, 200 kg.

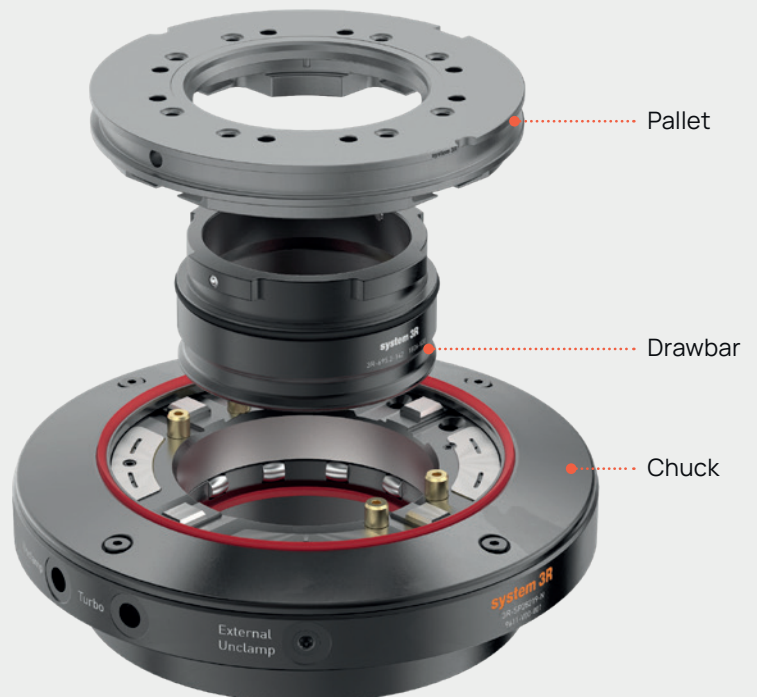

Matrix in detail

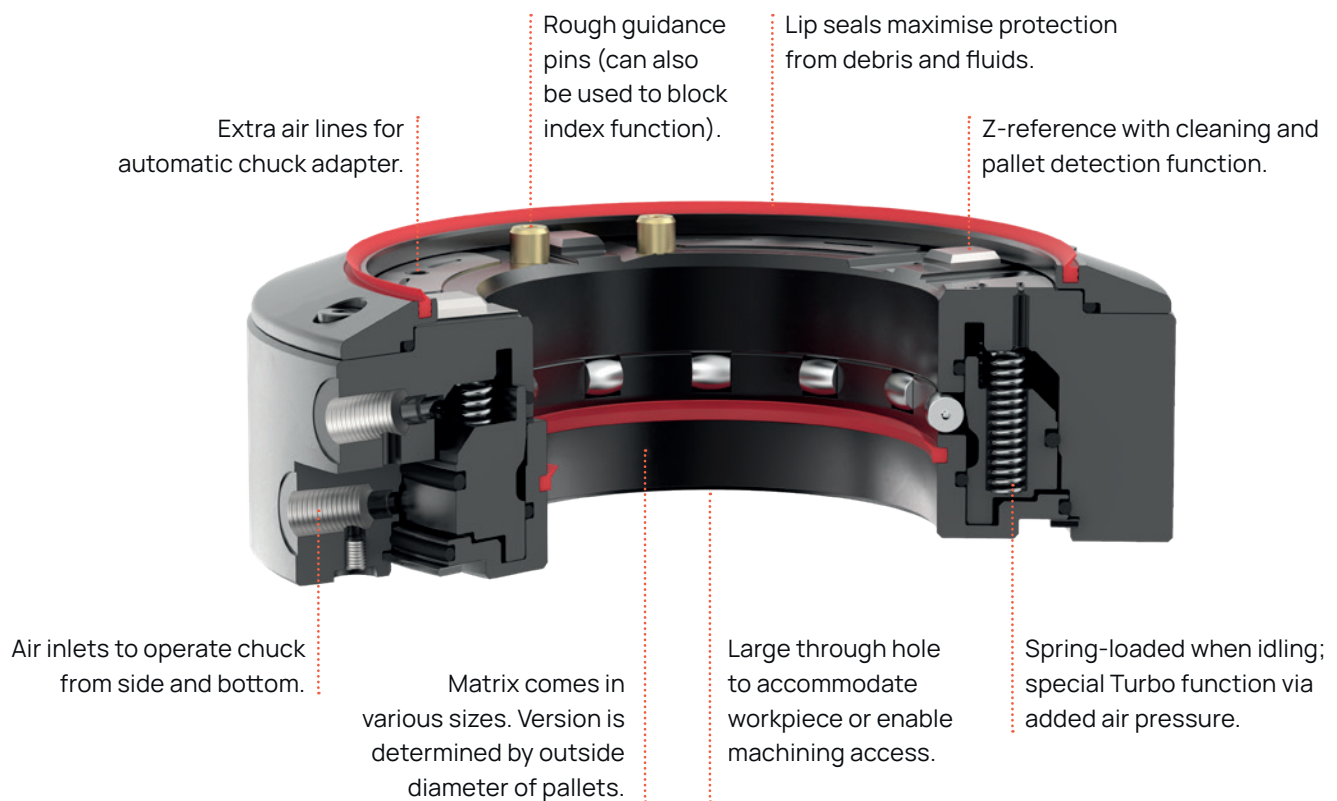

Matrix 110

Pneumatic chuck, Matrix 110, 3R-690.1-110

Chuck for permanent mounting on machine table.

- Fixed index positions 4x90°
- Clamping force 9,000 N
- Permissible torque 100 Nm
- Required drawbar 3R-695.2-110
- Required air pressure 6 bars (± 1)
- Weight 2.5 kg.

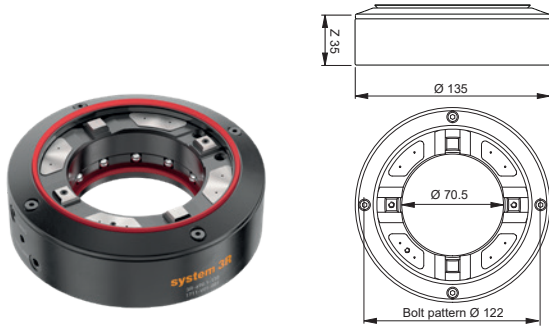

Pneumatic chuck, Matrix 110, 3R-690.1-110-RS

Chuck for permanent mounting on machine table.

- Fixed index positions 4x90°
- Rust resistant
- Clamping force 9,000 N
- Required drawbar 3R-695.2-110RS
- Required air pressure 6 bars (± 1)
- Weight 2.5 kg.

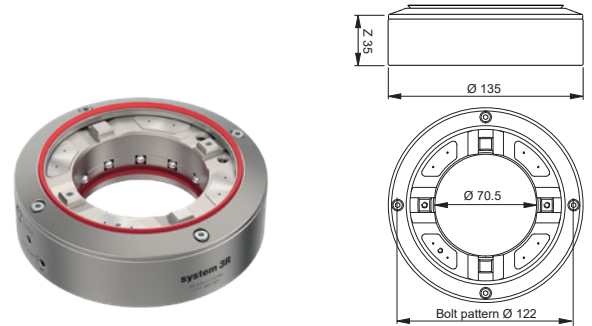

Pneumatic build-in chuck, Matrix 110, 3R-SP28395

Chuck for permanent mounting in machine table.

- Fixed index positions 4x90°
- Clamping force 9,000 N
- Permissible torque 100 Nm
- Required drawbar 3R-695.2-110
- Required air pressure, - 6 ± 1 bar
- Weight 2.7 kg.

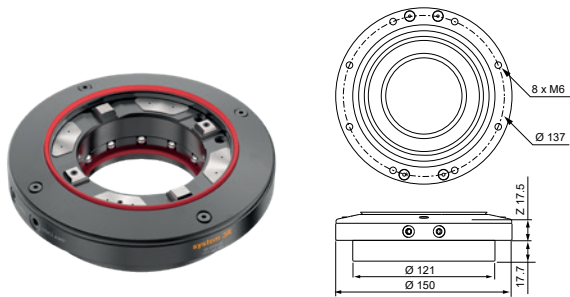

Pneumatic build-in chuck, Matrix 110, 3R-SP28395-RS

Chuck for permanent mounting in machine table.

- Fixed index positions 4x90°
- Rust resistant
- Hardened references
- Clamping force 9,000 N
- Required drawbar 3R-695.2-110RS
- Required air pressure, - 6 ± 1 bar
- Weight 2.7 kg.

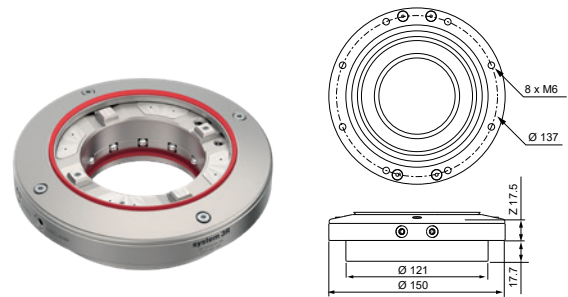

Drawbar, Matrix 110, 3R-695.2-110

- Weight 0.3 kg.

NOTE: In automated applications, the gripper has to grip the pallet and not the drawbar.

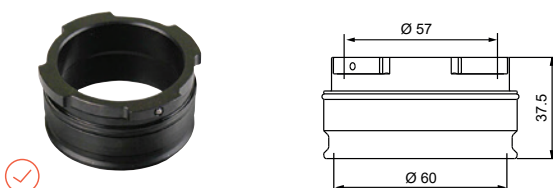

Drawbar, Matrix 110, 3R-695.2-110RS

- Rust resistant
- Weight 0.3 kg.

NOTE: In automated applications, the gripper has to grip the pallet and not the drawbar.

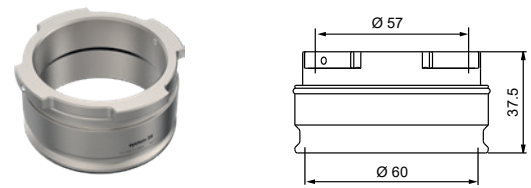

Matrix 110

Pallet, Matrix 110, 3R-691.1-110

- Fixed index positions 4x90°
- Permissible torque 100 Nm
- Required drawbar 3R-695.2-110 or similar
- Adapted for automatic changing
- Weight 0.5 kg.

NOTE: Not self carrying, requires extra support.

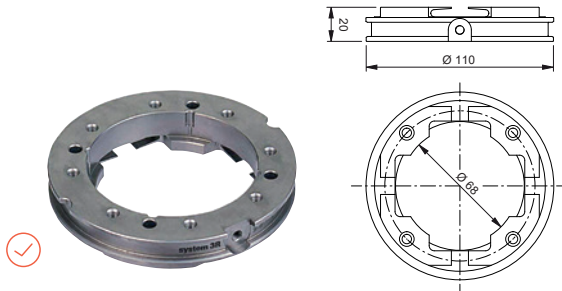

Check ruler, Matrix 110, 3R-696.1-110

For setting flatness and angular positions.

- Ground hole for centring.
- Ready for code carrier
- Measuring length 80 mm.
- Adapted for automatic changing
- Weight 1.6 kg.



Collet chuck ER20, Matrix 110, 3R-699.20-110D

Pallet can be flipped over to gain access from rear.

- Range for collets Ø 1-13 mm
- Recommended drawbar 3R-695.2-110
- Adapted for automatic changing
- Weight 1.3 kg.



Adapter, Matrix 110-Ø20, 3R-SP31380-RS

Intended to fit Ø 20 mm cutting tools. Also adapted to fit Ø 20 mm System 3R Mini electrode holders.

- Rust resistant
- Weight 2.9 kg.



Air gun interface, Matrix 110, 3R-SP29185

Dedicated attachment enabling use of air gun for 3R-690.1-110 and 3R-690.1-110-RS.

- Weight 0.5 kg.



Index blocker-pin, Matrix 110, 3R-SP29196

Blocks index functionality (by replacing two rough guidance pins).



Matrix 142

Pneumatic chuck, Matrix 142, 3R-690.1-142

Chuck for permanent mounting on machine table.

- Fixed index positions 4x90°
- Clamping force 15,000 N
- Permissible torque 300 Nm
- Required drawbar 3R-695.2-142
- Required air pressure 6 bars (± 1)
- Weight 7 kg.

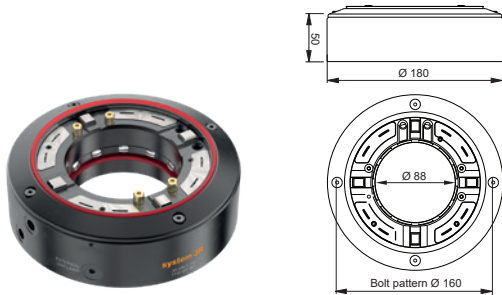

Pneumatic chuck, Matrix 142, 3R-690.1-142-RS

Rust resistant chuck for permanent mounting on machine table.

- Fixed index positions 4x90°
- Clamping force 15,000 N
- Required drawbar 3R-695.2-142RS
- Required air pressure 6 bars (± 1)
- Weight 7 kg.

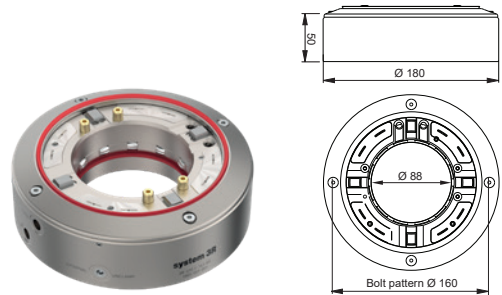

Pneumatic build-in chuck, Matrix 142, 3R-SP28219

Chuck for permanent mounting in machine table.

- Fixed index positions 4x90°
- Clamping force 15,000 N
- Permissible torque 300 Nm
- Required drawbar 3R-695.2-142
- Required air pressure 6 bars (± 1)
- Weight 7 kg.

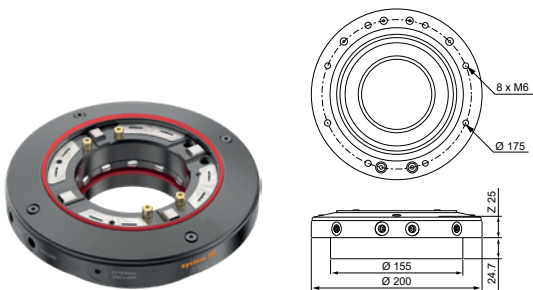

Pneumatic build-in chuck, Matrix 142, 3R-SP28219-RS

Rust resistant chuck for permanent mounting in machine table.

- Fixed index positions 4x90°
- Clamping force 15,000 N
- Permissible torque 300 Nm
- Required drawbar 3R-695.2-142RS
- Required air pressure 6 bars (± 1)
- Weight 7 kg.

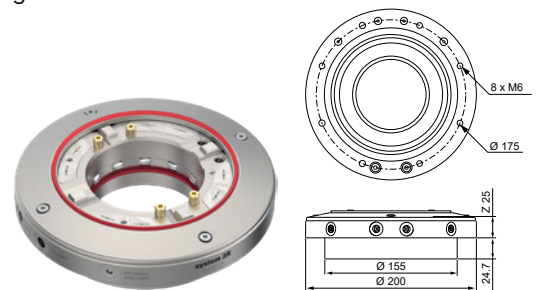

Drawbar, Matrix 142, 3R-695.2-142

- Weight 0.5 kg.

NOTE: In automated applications, the gripper has to grip the pallet and not the drawbar.

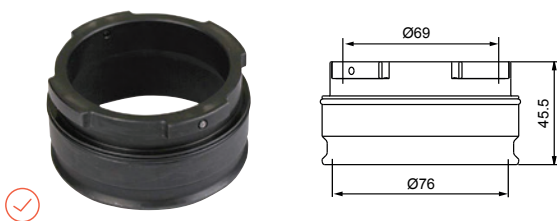

Drawbar, Matrix 142, 3R-695.2-142RS

- Rust resistant
- Weight 0.5 kg.

NOTE: In automated applications, the gripper has to grip the pallet and not the drawbar.

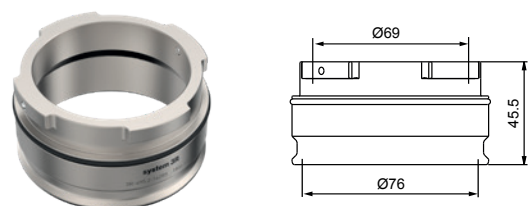

Matrix 142

Pallet, Matrix 142, 3R-691.1-142

- Fixed index positions 4x90°
- Permissible torque 300 Nm
- Required drawbar 3R-695.2-142 or similar
- Adapted for automatic changing
- Weight 1.2 kg.

NOTE: Not self carrying, requires extra support.

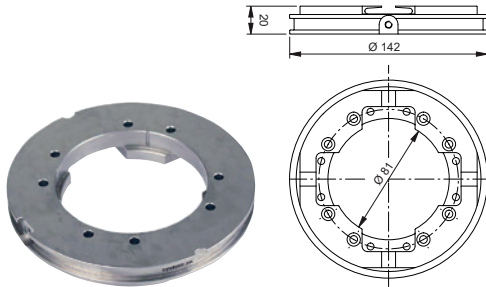

Check ruler, Matrix 142, 3R-696.1-142

For setting flatness and angular positions.
Ground hole for centering.

- Ready for code carrier
- Measuring length 100 mm
- Adapted for automatic changing
- Weight 3.4 kg.



Collet chuck ER20, Matrix 142, 3R-699.20-142D

Pallet can be flipped over to gain access from rear.

- Range for collets Ø 1-13 mm
- Recommended drawbar 3R-695.2-142
- Adapted for automatic changing
- Weight 3.1 kg.



Collet chuck ER40, Matrix 142, 3R-699.40-142D

Pallet can be flipped over to gain access from rear.

- Range for collets Ø 3-30 mm
- Recommended drawbar 3R-695.2-142
- Adapted for automatic changing
- Weight 3.4 kg.

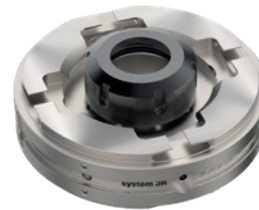

Adapter, Matrix 142-Capto C6, 3R-SP30752

From Matrix 142 to Capto C6 system.

- Rust resistant
- Recommended clamping torque 30 Nm
- Adapted for automatic changing
- Weight 3.9 kg.



Adapter, Matrix 142-Macro, 3R-SP30997

From Matrix 142 to Macro system.

- Required drawbar 3R-605.1
- Fixed index positions 4x90°
- Adapted for automatic changing
- Clamping force 6,000 N
- Permissible torque 300 Nm
- Required air pressure 6 bars (± 1)
- Weight 7 kg.

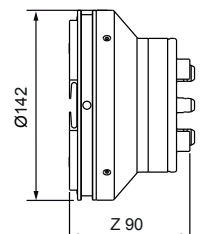

Matrix 142

Handle device, Matrix 142, 3R-692.7-142

A holding device for lifting pallets.

- Weight 0.9 kg.



Lifting aid, Matrix 142, 3R-692.8-142

Cradle to support 3R-692.7-110 and 3R-692.7-142 for lifting by crane.

- Weight 1.5 kg.



Index blocker-pin, Matrix 142, 3R-SP29533E

Blocks index functionality (by replacing two rough guidance pins).



Matrix application:

Pallet with special fixture for protruding workpiece, in this case a "hip joint".



Matrix 185

Pneumatic chuck, Matrix 185, 3R-690.1-185

Chuck for permanent mounting on machine table.

- Fixed index positions 4x90°
- Clamping force 20,000 N
- Permissible torque 600 Nm
- Required drawbar 3R-695.2-185
- Required air pressure 6 bars (± 1)
- Weight 9 kg.



Pneumatic chuck, Matrix 185, 3R-690.1-185-RS

Rust resistant chuck for permanent mounting on machine table.

- Fixed index positions 4x90°
- Clamping force 20,000 N
- Permissible torque 600 Nm
- Required drawbar 3R-695.2-185RS
- Required air pressure 6 bars (± 1)
- Weight 9 kg.

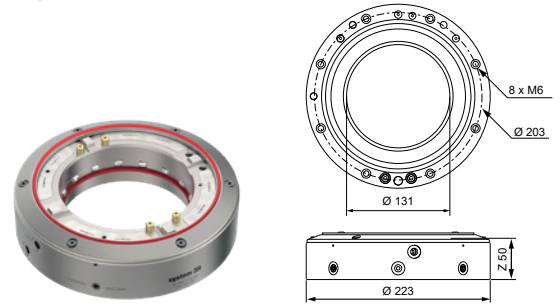

Pneumatic build-in chuck, Matrix 185, 3R-SP28268

Chuck for permanent mounting in machine table.

- Fixed index positions 4x90°
- Clamping force 20,000 N
- Permissible torque 600 Nm
- Required drawbar 3R-695.2-185
- Required air pressure 6 bars (± 1)
- Weight 10.6 kg.

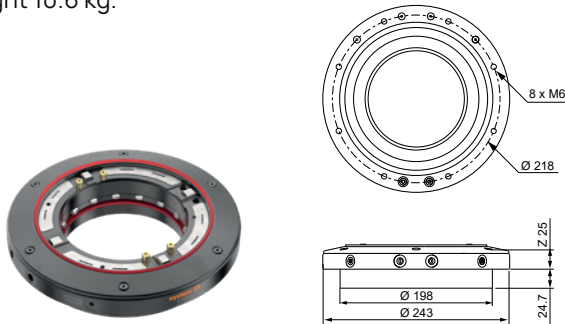

Pneumatic build-in chuck, Matrix 185, 3R-SP28268-RS

Rust resistant chuck for permanent mounting in machine table.

- Fixed index positions 4x90°
- Clamping force 20,000 N
- Required drawbar 3R-695.2-185RS
- Required air pressure 6 bars (± 1)
- Weight 10.6 kg.

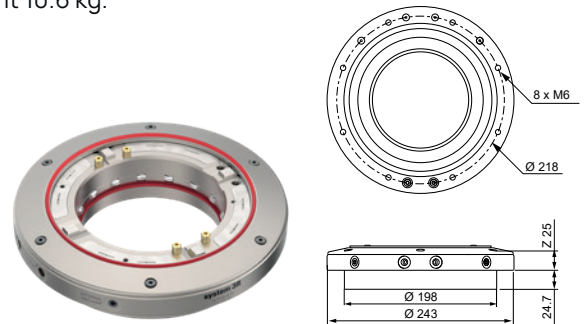

Drawbar, Matrix 185, 3R-695.2-185

- Weight 0.8 kg.

NOTE: In automated applications, the gripper has to grip the pallet and not the drawbar.

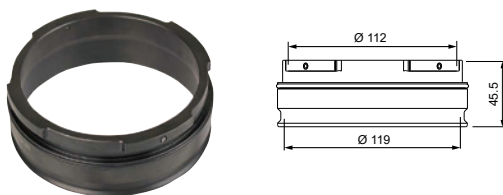

Drawbar, Matrix 185, 3R-695.2-185RS

- Rust resistant
- Weight 0.8 kg.

NOTE: In automated applications, the gripper has to grip the pallet and not the drawbar.

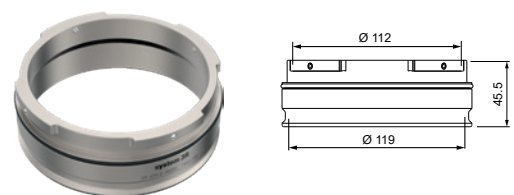

Matrix 185

Pallet, Matrix 185, 3R-691.1-185

- Fixed index positions 4x90°
- Permissible torque 600 Nm
- Required drawbar 3R-695.2-185 or similar
- Adapted for automatic changing
- Weight 1.7 kg.

NOTE: Not self carrying, requires extra support.

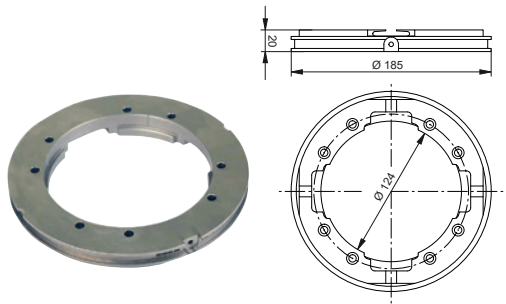

Check ruler, Matrix 185, 3R-696.1-185

For setting flatness and angular positions.
Ground hole for centring.

- Ready for code carrier
- Measuring length 125 mm
- Adapted for automatic changing
- Weight 5.7 kg.



Chuck adapter, Matrix 185-Macro, 3R-SP29998

From Matrix 185 into Macro system.

Chuck adapter with built-in Macro chuck.

- Required drawbar 3R-605.1
- Built in height 90 mm
- Hardened references
- Weight 8 kg.

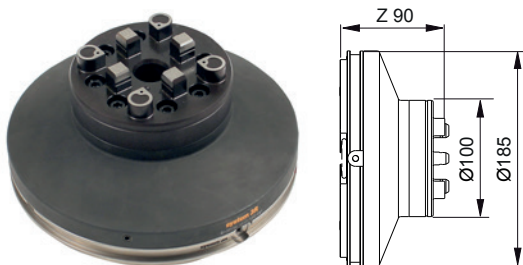

Handle device, Matrix 185, 3R-692.7-185

A holding device for lifting pallets.

- Weight 1.8 kg.



Lifting aid, Matrix 185, 3R-692.8-220

Cradle to support 3R-682.7-156, 3R-692.7-185 and 3R-692.7-220 for lifting by crane.

- Weight 2.5 kg.



Index blocker-pin, Matrix 185, 3R-SP29533E

Blocks index functionality (by replacing two rough guidance pins).



Matrix 220

Pneumatic chuck, Matrix 220, 3R-690.1-220

Chuck for permanent mounting on machine table.

- Fixed index positions 4x90°
- Clamping force 23,000 N
- Permissible torque 600 Nm
- Required drawbar 3R-695.2-220
- Required air pressure 6 bars (± 1)
- Weight 11 kg.



Pneumatic chuck, Matrix 220, 3R-690.1-220-RS

Rust resistant chuck for permanent mounting on machine table.

- Fixed index positions 4x90°
- Clamping force 23,000 N
- Permissible torque 600 Nm
- Required drawbar 3R-695.2-220RS
- Required air pressure 6 bars (± 1)
- Weight 11 kg.

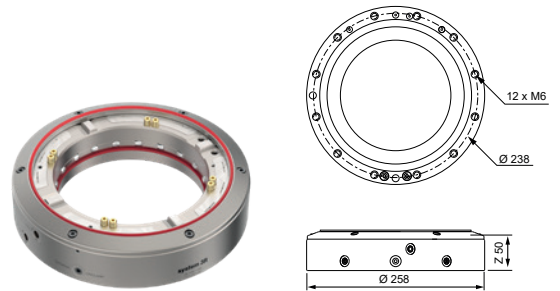

Pneumatic built-in chuck, Matrix 220, 3R-SP28340

Chuck for permanent mounting in machine table.

- Fixed index positions 4x90°
- Clamping force 23,000 N
- Permissible torque 600 Nm
- Required drawbar 3R-695.2-220
- Required air pressure 6 bars (± 1)
- Weight 10.6 kg.

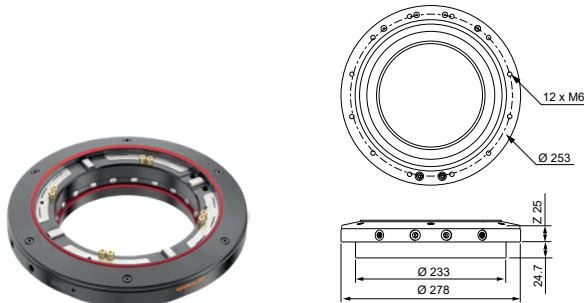

Pneumatic built-in chuck, Matrix 220, 3R-SP28340-RS

Rust resistant chuck for permanent mounting in machine table.

- Fixed index positions 4x90°
- Clamping force 23,000 N
- Permissible torque 600 Nm
- Required drawbar 3R-695.2-220RS
- Required air pressure 6 bars (± 1)
- Weight 10.6 kg.

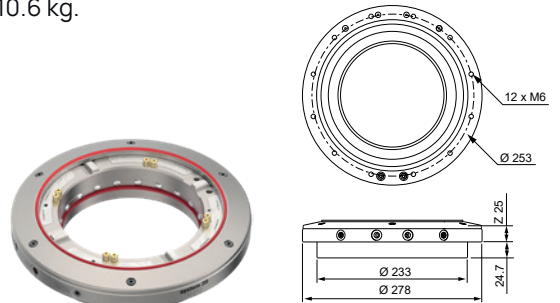

Drawbar, Matrix 220, 3R-695.2-220

- Weight 1.3 kg.

NOTE: In automated applications, the gripper has to grip the pallet and not the drawbar.

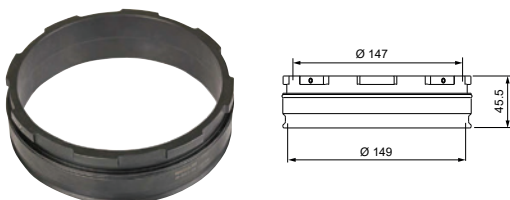

Drawbar, Matrix 220, 3R-695.2-220RS

- Rust resistant
- Weight 1.3 kg.

NOTE: In automated applications, the gripper has to grip the pallet and not the drawbar.

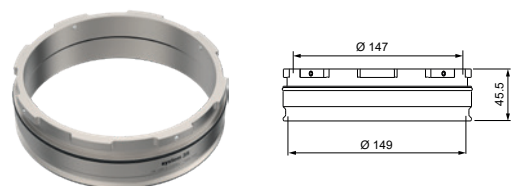

Matrix 220

Pallet, Matrix 220, 3R-691.1-220

- Fixed index positions 4x90°
- Permissible torque 600 Nm
- Required drawbar 3R-695.2-220 or similar
- Adapted for automatic changing
- Weight 2.6 kg.

NOTE: Not self carrying, requires extra support.

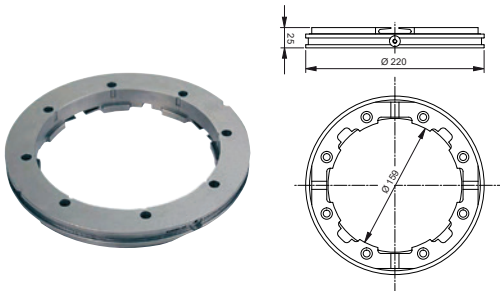

Check ruler, Matrix 220, 3R-696.1-220

For setting flatness and angular positions. Ground hole for centering.

- Ready for code carrier
- Measuring length 150 mm
- Adapted for automatic changing
- Weight 7.5 kg.

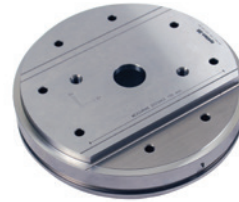

Matrix application:

To machine both sides of a workpiece, the pallet can be turned.

Air unit, 3R-611.2

Foot operation of pneumatic chucks.

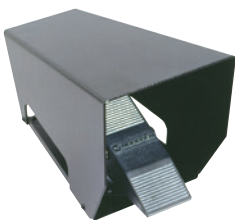

Air unit, 3R-611.4

Unit for operation of pneumatic chucks. Two functions, open/close.



Code carriers, 3R-863.01-10

With pre-programmed unique identity, designed for use on pallets.

- Supplied in sets of 10.



Matrix 220 accessories

Handle device, Matrix 220, 3R-692.7-220

A holding device for lifting pallet.

- Weight 1.5 kg.



Lifting aid, Matrix 220, 3R-692.8-220

Cradle to support 3R-682.7-156, 3R-692.7-185 and 3R-692.7-220 for lifting by crane.

- Weight 2.5 kg.



Index blocker-pin, Matrix 220, 3R-SP29559E

Blocks index functionality (by replacing four rough guidance pins).

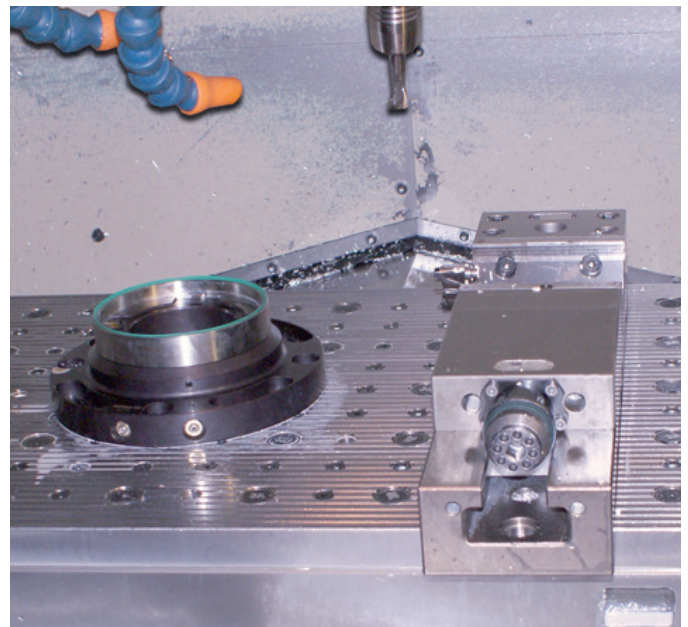

Matrix 260

Pneumatic chuck, Matrix 260, 3R-690.1-260

Chuck for permanent mounting on the machine table.

- Fixed index positions 4x90°
- Clamping force 28 000 N
- Permissible torque 600 Nm
- Required drawbar 3R-695.2-260
- Required air pressure 6 bars (± 1)
- Weight 13 kg.

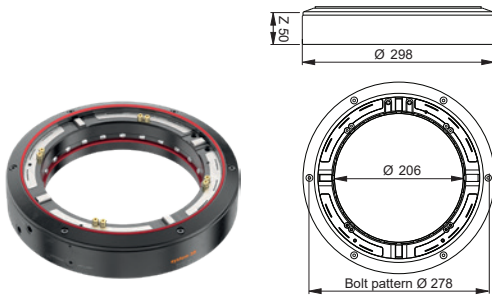

Pneumatic built-in chuck, Matrix 260, 3R-SP28345

Chuck for permanent mounting in the machine table.

- Fixed index positions 4x90°
- Clamping force 28 000 N
- Permissible torque 600 Nm
- Required drawbar 3R-695.2-260
- Required air pressure 6 bars (± 1)
- Weight 12.6 kg.

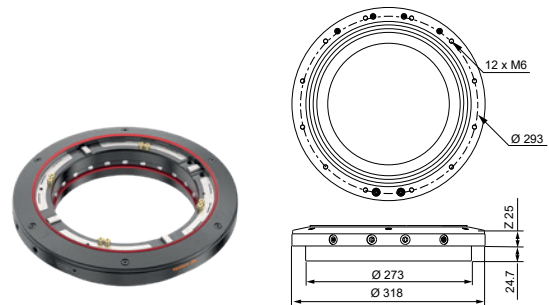

Pallet, Matrix 260, 3R-691.1-260

- Fixed index positions 4x90°
- Permissible torque 600 Nm
- Required drawbar 3R-695.2-260 or similar
- Adapted for automatic changing
- Weight 3.2 kg.

NOTE: Not self carrying, requires extra support.

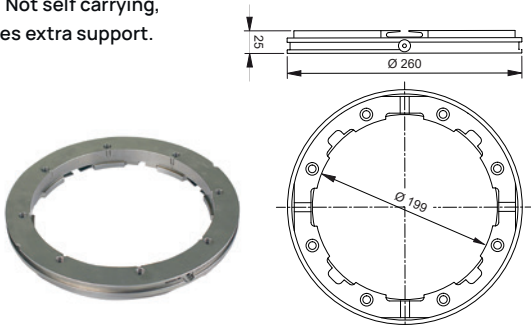

Drawbar, Matrix 260, 3R-695.2-260

- Weight 1.5 kg.

NOTE: In automated applications, the gripper has to grip the pallet and not the drawbar.

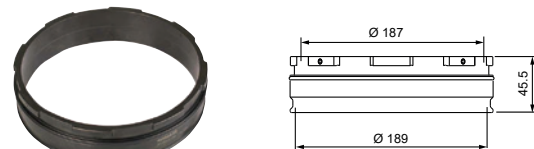

Check ruler, Matrix 260, 3R-696.1-260

For setting flatness and angular positions. Ground hole for centring.

- Ready for code carrier
- Measuring length 200 mm
- Adapted for automatic changing
- Weight 10 kg.

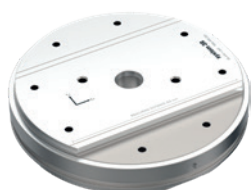

Index blocker-pin, Matrix 260, 3R-SP29559E

Blocks index functionality (by replacing four rough guidance pins).



MatrixNano

Measures to reduce the downtime of your machines are significantly more worthwhile than chasing seconds in the actual machining process. What matters is keeping machines running. This is when you need an interface that enables rapid set-up.

The Matrix system is just such an interface. While machines are working on one job, upcoming jobs are set up in parallel away from them. The set-up for each new job is then installed in the stationary machine in a matter of seconds. Important for long runs, but crucial for the profitability of short runs or one-off production.

System design has been optimised for metal-cutting machining and is ideal for work involving high machining forces. The drawbar's generous diameter means short distances between references and applied locking force. This gives maximum stability and accuracy. The inherent advantages of the Matrix system truly come into their own in tough machining applications.

As well as extreme accuracy, Matrix features low construction height, ultra-precise indexing and a drawbar with through hole. The through hole allows high/long workpieces to be sunk into the chuck for stable/rigid mounting.

Repetition accuracy:

- Matrix 110 Nano and Matrix 142 Nano within 0.001 mm.
- Fixed index positions 4x90°.
- Required air pressure, pneumatic chuck: 6±1 bar
- Clamping force:
 - Matrix 110, 9,000 N
 - Matrix 142, 15,000 N
- Max workpiece weight (manual loading):
 - Matrix 110, 50 kg
 - Matrix 142, 100 kg

ADVANTAGES

- Reduces set-up times.
- Ensures precision and quality.
- Has automatic air-blast cleaning of the references.
- Is sealed against dirt and swarf; withstands harsh work environments.
- Has enhanced clamping force (turbo locking).
- Is suitable for automatic changing with System 3R's automation program.

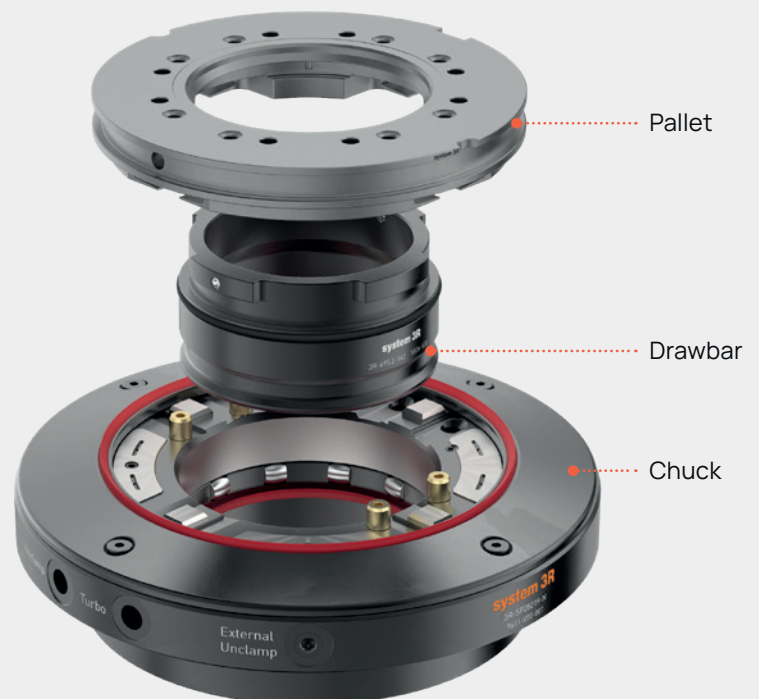

MatrixNano in detail

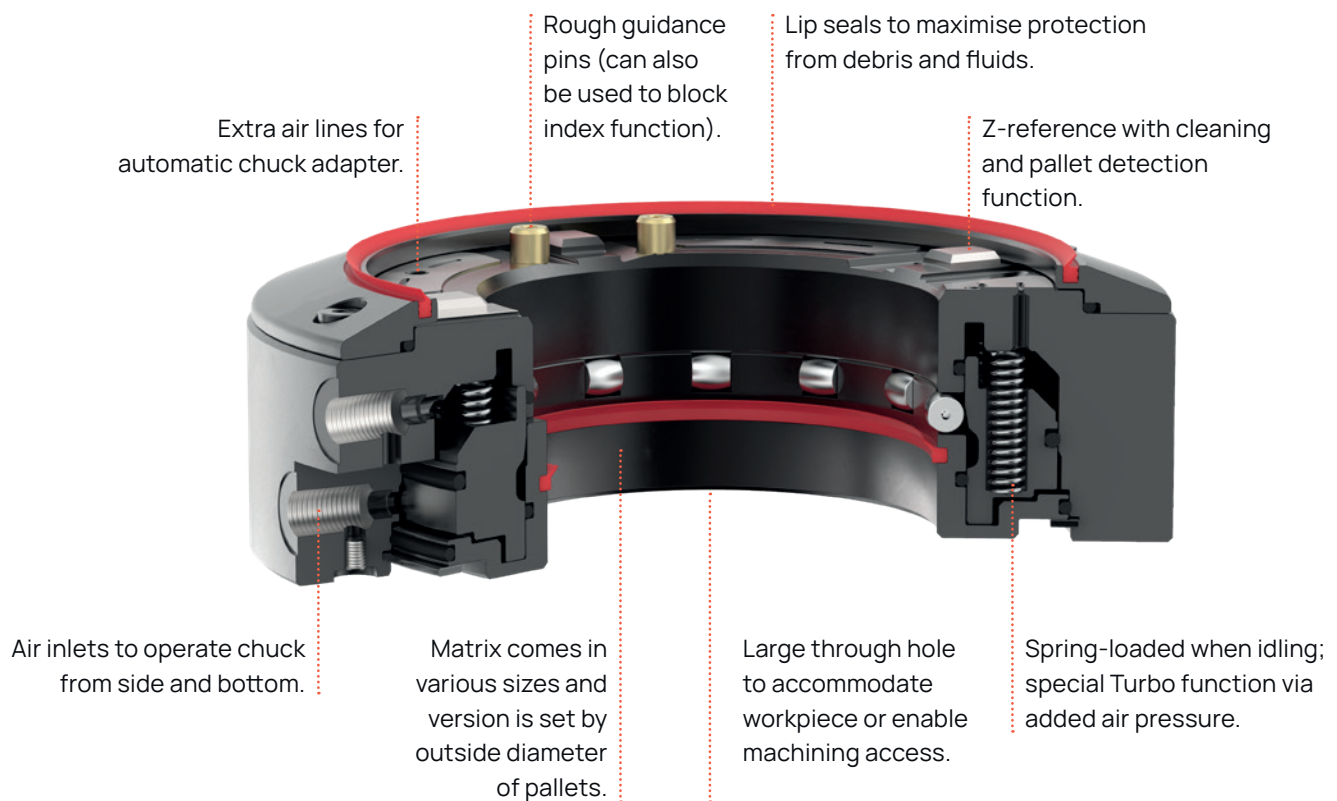

Matrix 110 Nano

Pneumatic chuck, Matrix 110 Nano, 3R-690.1-110-N

Chuck for permanent mounting on machine table.

- Fixed index positions 4x90°
- Clamping force 9,000 N
- Permissible torque 100 Nm
- Required drawbar 3R-695.2-110
- Required air pressure 6 bars (± 1)
- Weight 2.5 kg.



NANO

Pneumatic chuck, Matrix 110 Nano, 3R-690.1-110-RS-N

Chuck for permanent mounting on machine table.

- Fixed index positions 4x90°
- Rust resistant
- Clamping force 9,000 N
- Required drawbar 3R-695.2-110RS
- Required air pressure 6 bars (± 1)
- Weight 2.5 kg.

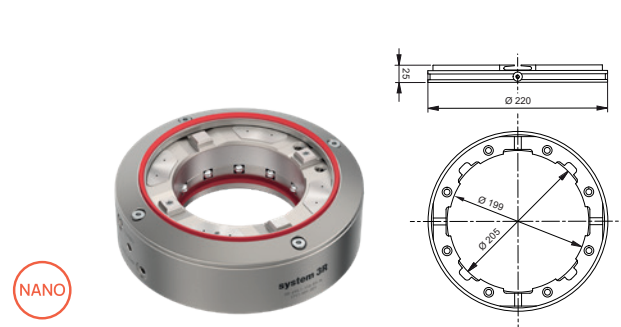

NANO

Pneumatic build-in chuck, Matrix 110 Nano, 3R-SP28395-N

Chuck for permanent mounting in machine table.

- Fixed index positions 4x90°
- Clamping force 9,000 N
- Permissible torque 100 Nm
- Required drawbar 3R-695.2-110
- Required air pressure, - 6 \pm 1 bar
- Weight 2.7 kg.

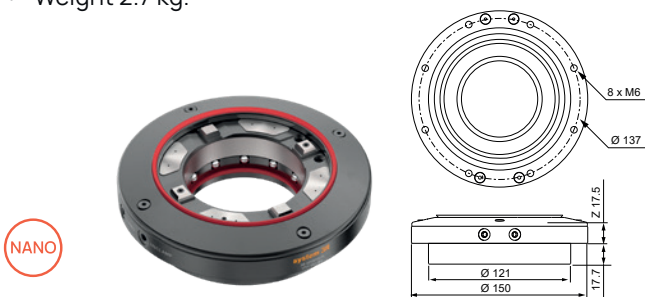

NANO

Pneumatic build-in chuck, Matrix 110 Nano, 3R-SP28395-RS-N

Chuck for permanent mounting in machine table.

- Fixed index positions 4x90°
- Clamping force 9,000 N
- Permissible torque 100 Nm
- Required drawbar 3R-695.2-110RS
- Required air pressure, - 6 \pm 1 bar
- Weight 2.7 kg.

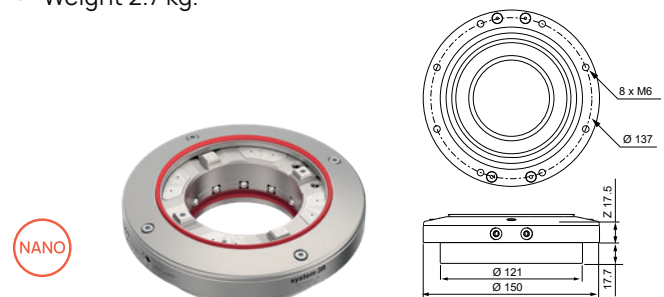

NANO

Pallet, Matrix 110 Nano, 3R-691.1-110-N

- Fixed index positions 4x90°
- Permissible torque 100 Nm
- Required drawbar 3R-695.2-110 or similar
- Adapted for automatic changing
- Weight 0.5 kg.

NOTE: Not self carrying, requires extra support.

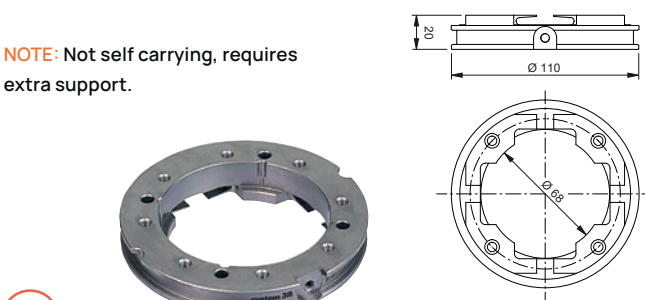

NANO

Check ruler, Matrix 110 Nano, 3R-696.1-110-N

For setting flatness and angular positions.

- Ground hole for centring.
- Ready for code carrier
- Measuring length 80 mm
- Adapted for automatic changing
- Weight 1.6 kg.



NANO

Matrix 142 Nano

Pneumatic build-in chuck, Matrix 142 Nano, 3R-SP28219-N

Chuck for permanent mounting in machine table.

- Fixed index positions 4x90°
- Clamping force 15,000 N
- Permissible torque 300 Nm
- Required drawbar 3R-695.2-142
- Required air pressure 6 bars (± 1)
- Weight 7 kg.

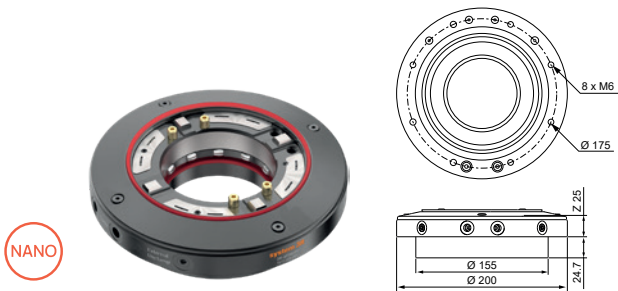

Pneumatic build-in chuck, Matrix 142 Nano, 3R-SP28219-RS-N

Rust-resistant chuck for permanent mounting in machine table.

- Fixed index positions 4x90°
- Clamping force 15,000 N
- Permissible torque 300 Nm
- Required drawbar 3R-695.2-142RS
- Required air pressure 6 bars (± 1)
- Weight 7 kg.

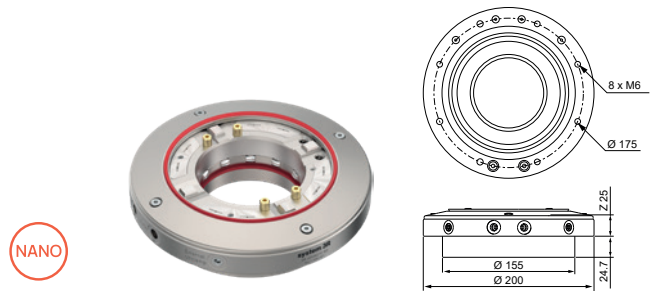

Pneumatic chuck, Matrix 142 Nano, 3R-690.1-142-N

Chuck for permanent mounting on machine table.

- Fixed index positions 4x90°
- Clamping force 15,000 N
- Permissible torque 300 Nm
- Required drawbar 3R-695.2-142
- Required air pressure 6 bars (± 1)
- Weight 7 kg.



Pallet, Matrix 142 Nano, 3R-691.1-142-N

- Fixed index positions 4x90°
- Permissible torque 300 Nm
- Required drawbar 3R-695.2-142 or similar
- Adapted for automatic changing
- Weight 1.2 kg.

NOTE: Not self carrying, requires extra support.

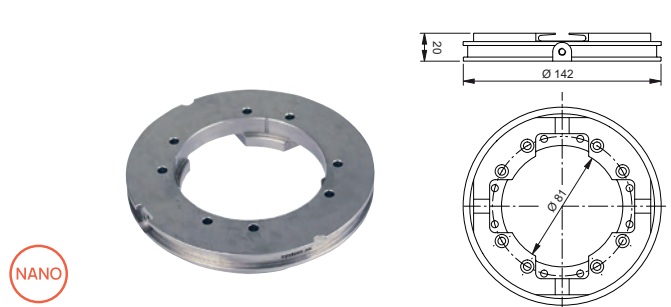

Check ruler, Matrix 142 Nano, 3R-696.1-142-N

For setting flatness and angular positions.

- Ground hole for centring.
- Ready for code carrier
- Measuring length 100 mm
- Adapted for automatic changing
- Weight 3.4 kg.

