

System 3R – Tooling

DelphinShort frames for MITSUBISHI WEDM

MP1200 / MP2400 / MV1200R / MV2400R



System 3R

When all you need is everything, it's good to know that there is one company that you can count on to deliver complete solutions and services. System 3R equips world-class electrical discharge machines (EDM), Laser texturing and Additive Manufacturing through to first-class Milling by Tooling, Automation and software systems — all backed by unrivalled customer service and support — we, help you raise your game and increase your competitive edge.

System 3R design and quality



Contents

4	Frame components
8	Frame tooling for MITSUBISHI MP1200
10	Frame tooling for MITSUBISHI MP2400
12	Frame tooling for MITSUBISHI MV1200R
14	Frame tooling for MITSUBISHI MV2400R
16	Frame Tooling accessories
18	DelphinShort introduction
19	DelphinShort chucks
21	DelphinShort for automation and manual applications
22	DelphinShort drawbars
24	DelphinShort accessories
25	Contents

Frames for MITSUBISHI WEDM

Large palletising systems adapted to the WEDM machine table dimensions



Frames

The rugged design enables large workpieces to be clamped and changed in the WEDM machine with repeatable accuracy.

Adjusting/designing the clamping bars to the specific workpieces significantly reduces the clamping and alignment effort.

Components

The basic frame equipment comprises the following components:

- + Machine equipment
- + Pneumatic control
- + Frame
- + Clamping bars



Options

The frame equipment can be complemented with the following components if desired:

- + Gripper (to robot or lifting device)
- + Presetting station
- + Machine equipment to measuring machine

Frames for MITSUBISHI WEDM



Machine equipment

The machine equipment consist of two identical DelphinShort Twin Baseplates and where from the size of the machine table frame reasonable and feasible corner and middle Z-supports. The two DelphinShort Twin Baseplates build the reference clamping system for the DelphinShort Frame on the WEDM machine. They guarantee best possible repetition accurarcy and strong fixation of the DelphinShort Frame on the WEDM machine. The corner Z-supports are used on the table to give more stability to the on the machine clamped frame. The middle Z-supports help to reduce the deflection of a heavy loaded DelphinShort Frame.

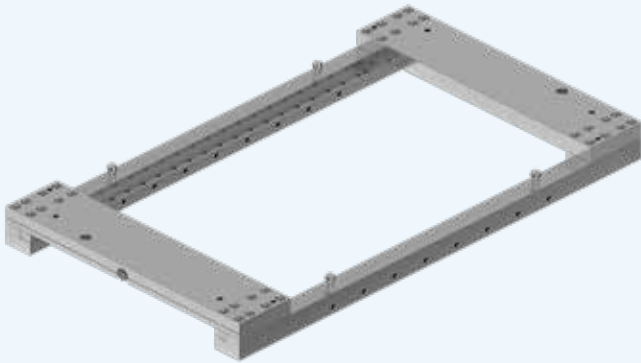

Frame

This is the „pallet“ in a frame equipment. It includes the reference elements which define the position of the frame on the WEDM machine table along with the chucks. It is also the carrier element for the different clamping bars.

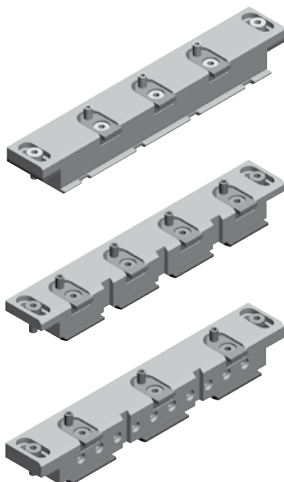

Clamping bars

Mounted into the frame, these provide the actual workpiece clamping, either singly or normally as a pair. System 3R provides three types of clamping bars as standard, each as single or double-sided versions.

- + Clamping bar with fixed support lips: workpiece can be clamped at „0“ or collision-free at „+4“ using spacer plates (included)
- + Clamping bar with screwed support lips: depending on the type of support lips, workpiece can be clamped at „0“ or collision-free at „+4“
- + Combi clamping bar with screwed support lips: workpiece is clamped at „0“ or collision-free at „+4“ Combi clamping bars are prepared for using the 3R-239 ruler accessory.

Frames for MITSUBISHI WEDM



DelphinShort reference ruler

This reference element for the machine equipment is used for the following:

- + Enables quick, simple and top-precision mounting and alignment of both DelphinShort Twin Baseplates on the WEDM machine table.
- + Checking and readjustment of the machine equipment on the WEDM machine table



Pneumatic control system

This system is required for controlling the two DelphinShort Twin Baseplates on the machine equipment in order to clamp or release the frame on the machine. It also supplies the Z-supports with cleaning air.

All tubings and air distribution blocs are included in the machine equipment and ready to be connected to the controls of the automation.

For non automated operation we have a specific manual 3-way pneumatic valve in the portfolio.



Set of clamping screws / brackets

The clamping bars are all fitted with brackets which allow plates and workpieces of 15 – 30 mm thickness to be clamped. For clamping thinner or thicker plates and parts the set of clamping screws / brackets provides the required screws, set screws and brackets in stainless steel.

Frames

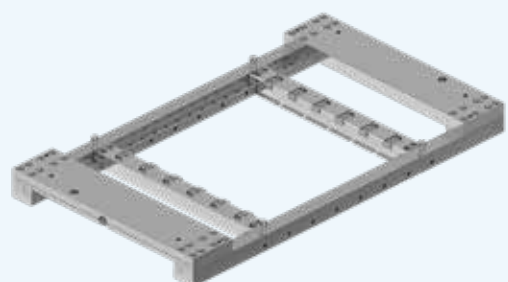
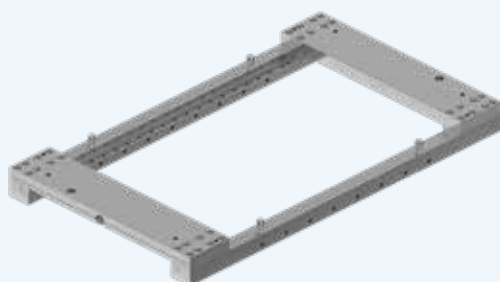

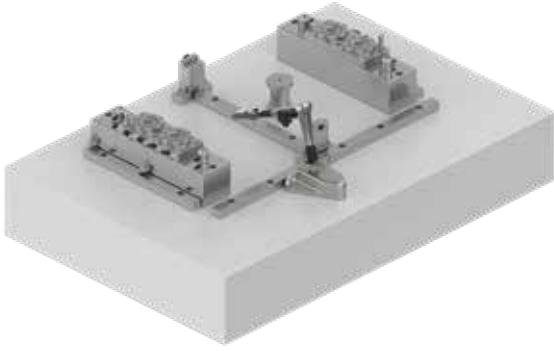

Presetting station

The presetting station enables the frame to be loaded and unloaded with work-pieces outside the WEDM machine. However, the main use of the presetting station is to align the workpieces very precisely level and plane-parallel to the stone plate in the frame.

The entire set-up on the stone plate can also be mounted directly on a 3D measuring machine. This enables the work-pieces to be measured while clamped in the frame.



Gripper

A gripper fitted to the size of the frame is required for handling the frame with a robot or a handling device (automatic or manual). These grippers are purely mechanical fork or trapezoid grippers which operate without any external power.



Manual Handling

We recommend using a lifting device with an adjustment for the lifting interface on the frame when manual handling the frame.



Single-sided clamping bar.

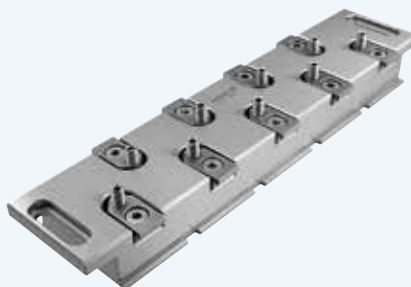

Double-sided clamping bar .

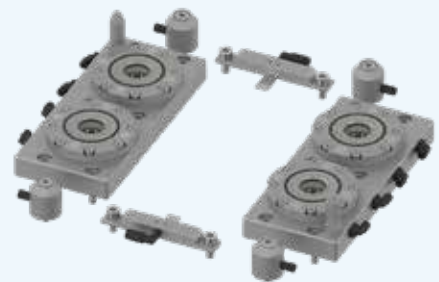

Machine equipment DelphinShort.

MITSUBISHI MP1200

Frames, accessories and layouts



MITSUBISHI MP1200 – Basic WEDM frame tooling

Description	Art. number
Machine equipment Makino MITSUBISHI MP1200	C 953 100
Frame MITSUBISHI MP1200	C 953 140
PN valve for manual operations	C 254 960
Clamping bar 320, lips screwed, single	C 917 130
Clamping bar 320, lips screwed, double	C 917 140

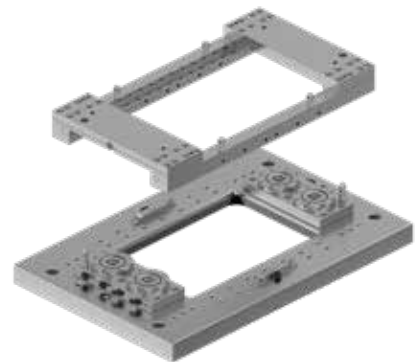

MP1200 – WEDM Frame tooling.

MITSUBISHI MP1200 – WEDM frame tooling accessories

Description	Art. number
Frame presetting station	C 953 180
Stand for presetting station 1200 x 800	V 000 019
Reference ruler for Frames	C 953 150
Set of clamping screws / brackets	C 860 200

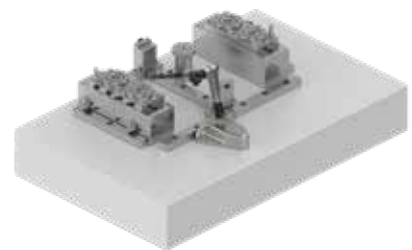

MP1200 – Frame presetting station.

MITSUBISHI MP1200 – WEDM Frame tooling

Machine equipment C 953 100

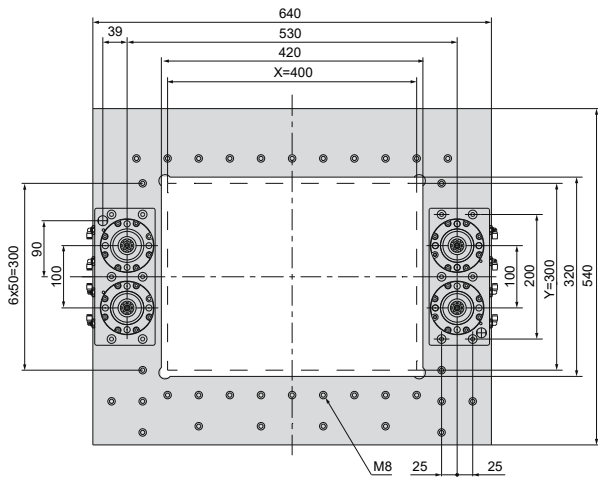

Frame C 953 140

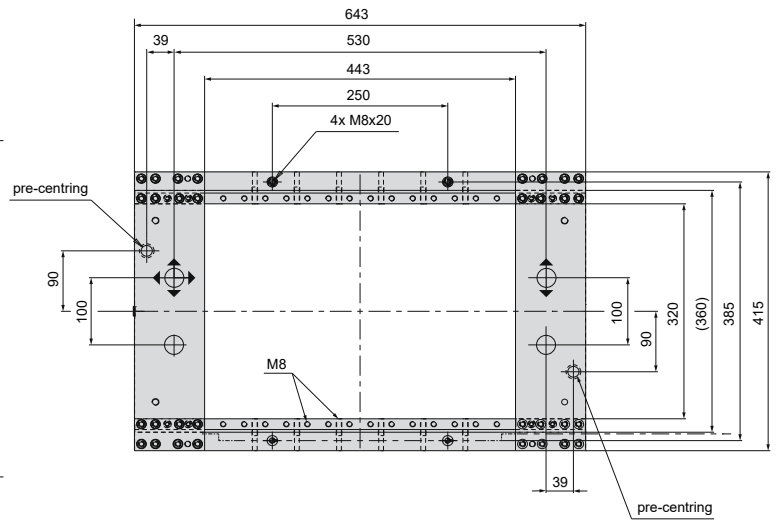

Clamping bar 320

Lips screwed
C 917 130
C 917 140

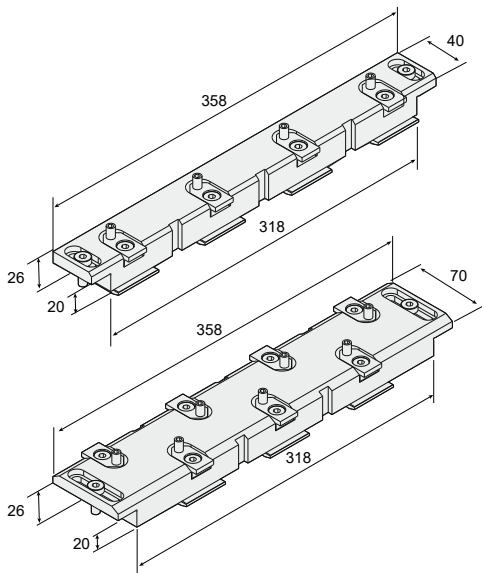

Presetting station

C 953 180 Frame presetting station
V 000 019 Stand for presetting station 1200 x 800

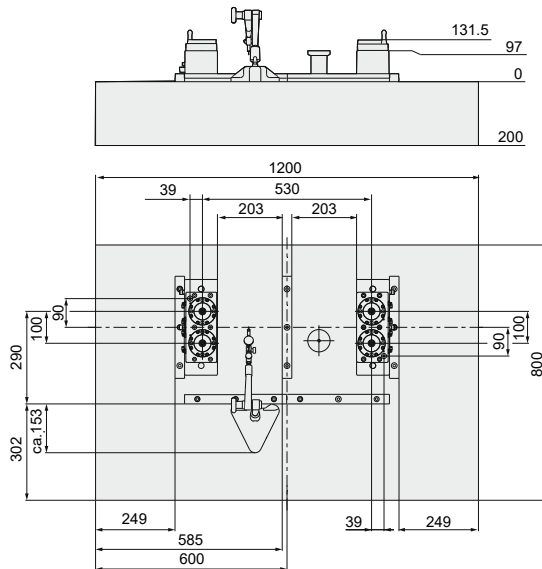

MITSUBISHI MP2400

Frames, accessories and layouts



MITSUBISHI MP2400 – Basic WEDM frame tooling

Description	Art. number
Machine equipment MITSUBISHI MP2400	C 953 200
Frame MITSUBISHI MP2400	C 953 240
PN valve for manual operations	C 254 960
Clamping bar 420, lips screwed, single	C 917 150
Clamping bar 420, lips screwed, double	C 917 160

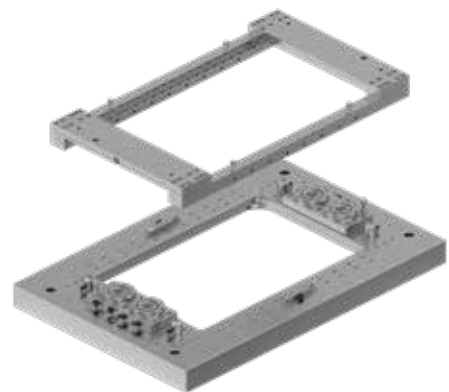

MP2400 – WEDM Frame tooling.

MITSUBISHI MP2400 – WEDM frame tooling accessories

Description	Art. number
Frame presetting station	C 953 280
Stand for presetting station 1500 x 1000	V 000 021
Reference ruler for Frames	C 953 250
Set of clamping screws / brackets	C 860 200

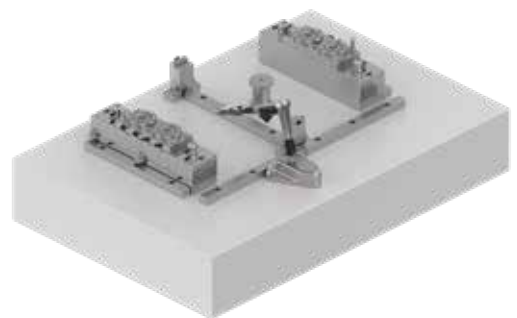

MP2400 – Frame presetting station.

MITSUBISHI MP2400 – WEDM Frame tooling

Machine equipment C 953 200

Frame C 953 240

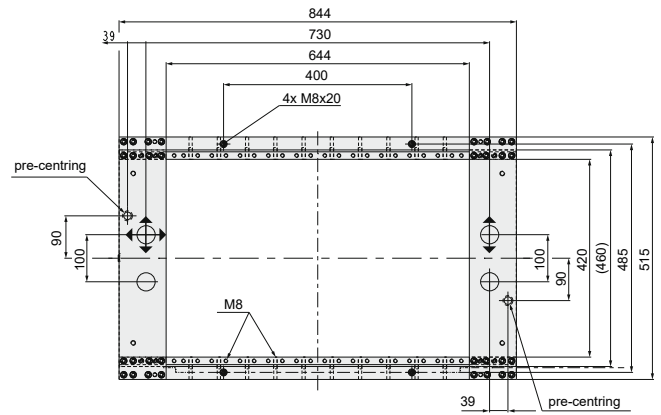
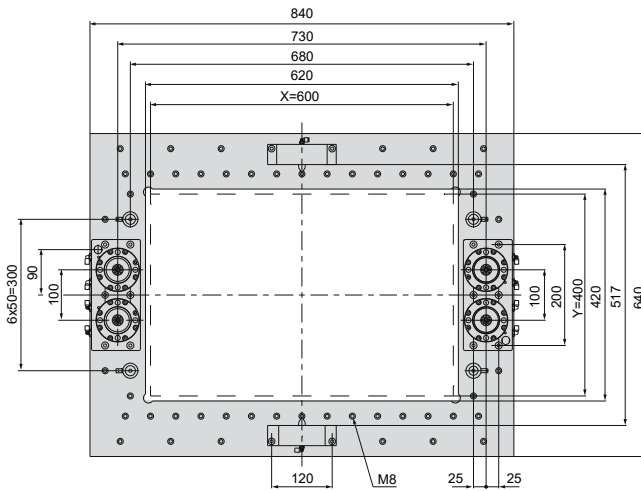

Clamping bar 420

Lips screwed
C 917 150
C 917 160

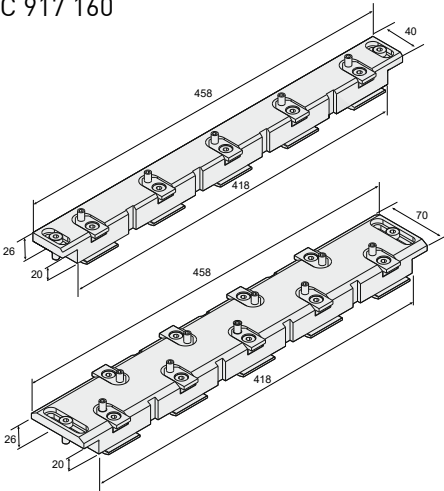

Presetting station

C 953 280 Frame presetting station
V 000 021 Stand for presetting station 1500 x 1000

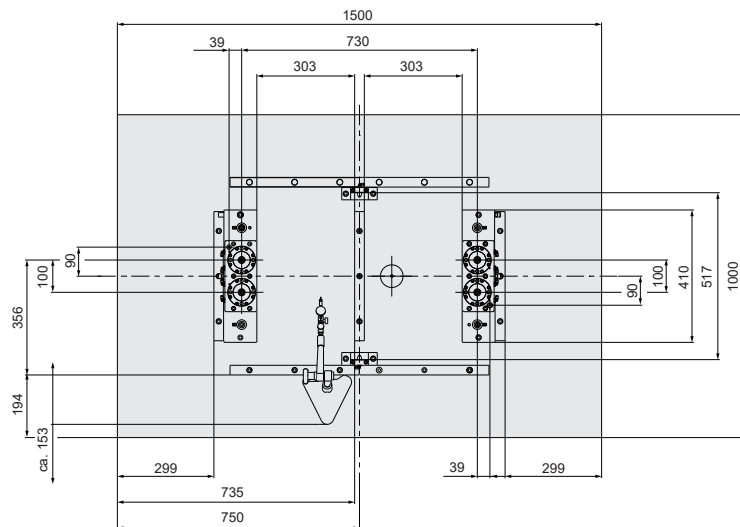
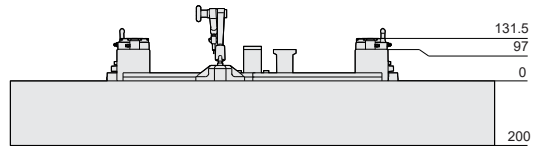

MITSUBISHI MV1200R

Frames, accessories and layouts



MITSUBISHI MV1200R – Basic WEDM frame tooling

Description	Art. number
Machine equipment MITSUBISHI MV1200R	C 953 100
Frame MITSUBISHI MV1200R	C 952 140
PN valve for manual operations	C 254 960
Clamping bar 320, lips screwed, single	C 917 130
Clamping bar 320, lips screwed, double	C 917 140

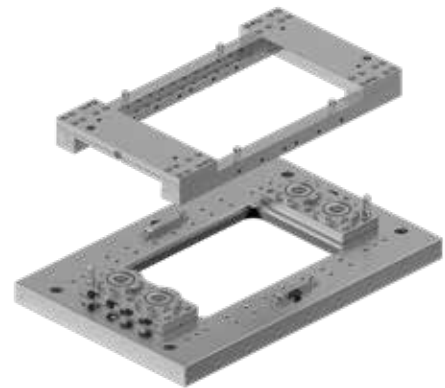

MITSUBISHI MV1200R – WEDM Frame tooling.

MITSUBISHI MV1200R – WEDM frame tooling accessories

Description	Art. number
Frame presetting station	C 953 180
Stand for presetting station 1200 x 800	V 000 019
Reference ruler for Frames	C 953 150
Set of clamping screws / brackets	C 860 200

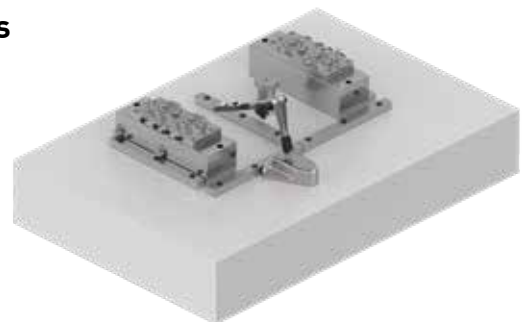

MITSUBISHI MV1200R – Frame presetting station.

MITSUBISHI MV1200R – WEDM FRAME TOOLING

Machine equipment C 953 100

Frame C 953 140

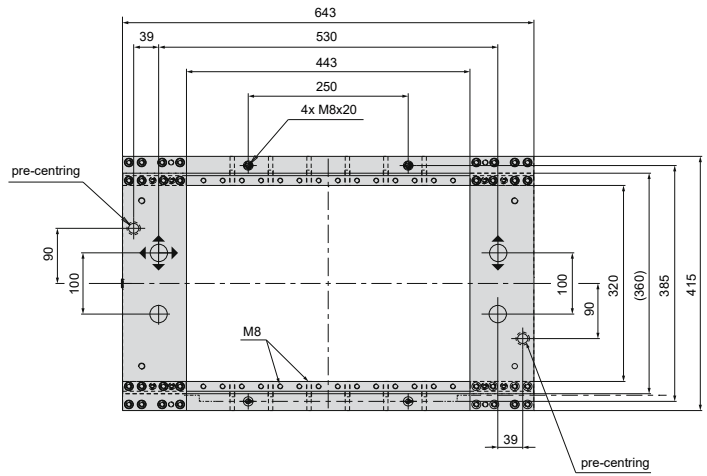
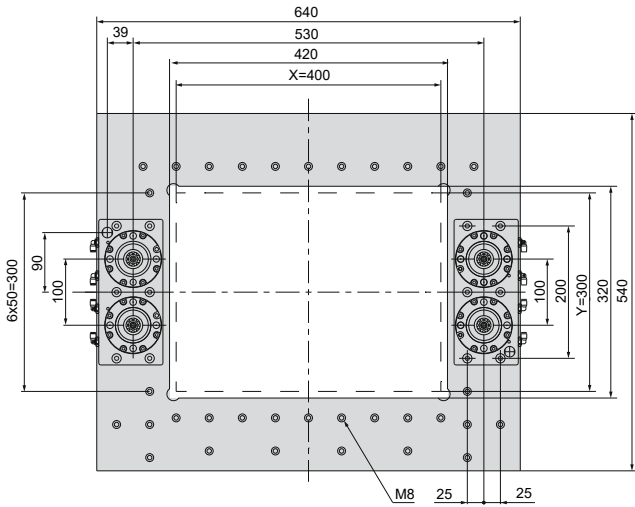

Clamping bar 320

Lips screwed
C 917 130
C 917 140

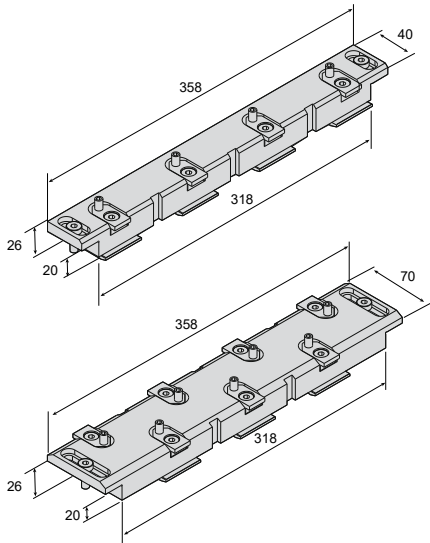

Presetting station

C 953 180 Frame presetting station
V 000 019 Stand for presetting station 1200 x 800

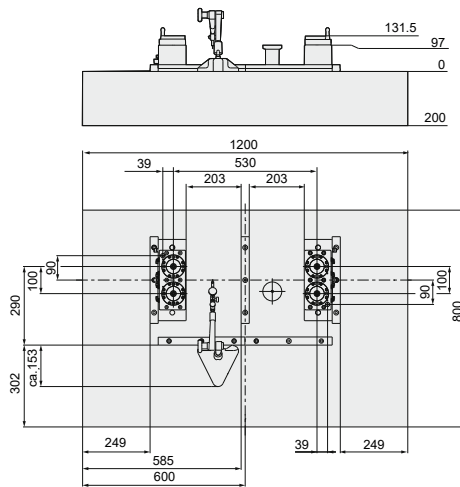

MITSUBISHI MV2400R

Frames, accessories and layouts



MITSUBISHI MV2400R – Basic WEDM frame tooling

Description	Art. number
Machine equipment MITSUBISHI MV2400R	C 953 200
Frame MITSUBISHI MV2400R	C 953 240
PN valve for manual operations	C 254 960
Clamping bar 420, lips screwed, single	C 917 150
Clamping bar 420, lips screwed, double	C 917 160

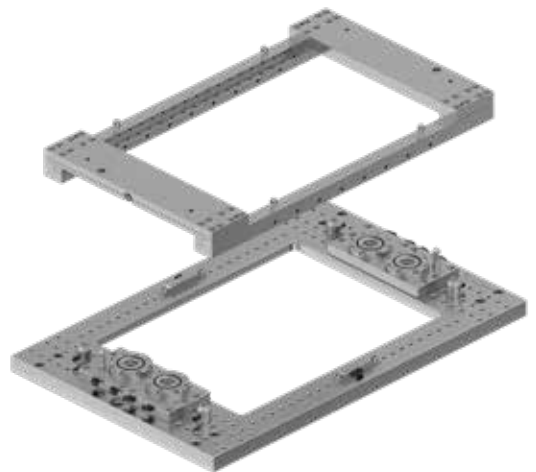

MITSUBISHI MV2400R – WEDM Frame tooling.

MITSUBISHI MV2400R – WEDM frame tooling accessories

Description	Art. number
Frame presetting station	C 953 280
Stand for presetting station 1500 x 1000	V 000 021
Reference ruler for Frames	C 953 250
Set of clamping screws / brackets	C 860 200

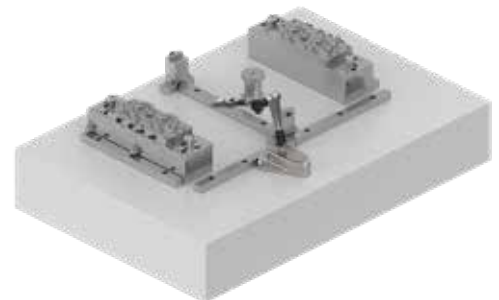

MITSUBISHI MV2400R – Frame presetting station.

MITSUBISHI MV2400R – WEDM frame tooling

Machine equipment C 953 200

Frame C 953 240

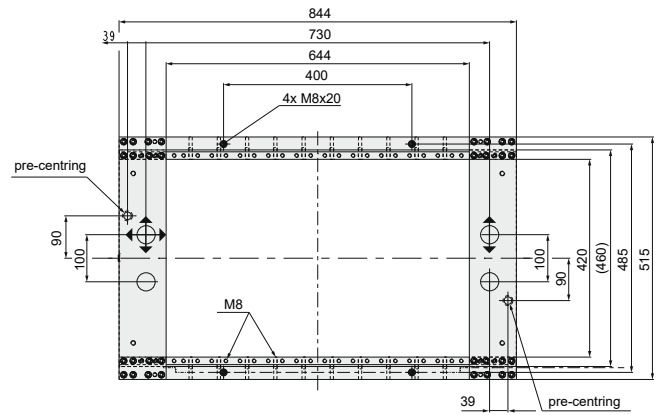
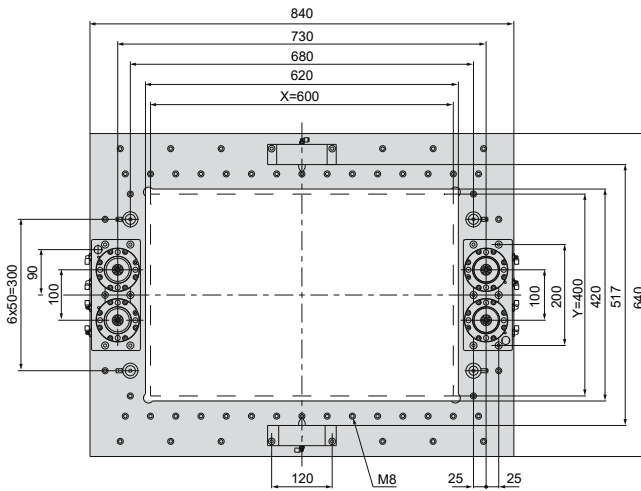

Clamping bar 420

Lips screwed
C 917 150
C 917 160

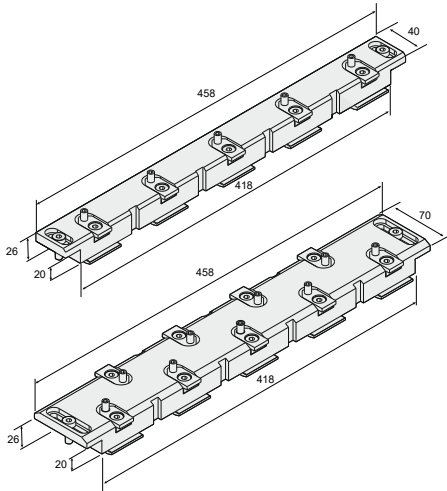

Presetting station

C 953 280 Frame presetting station
V 000 021 Stand for presetting station 1500 x 1000

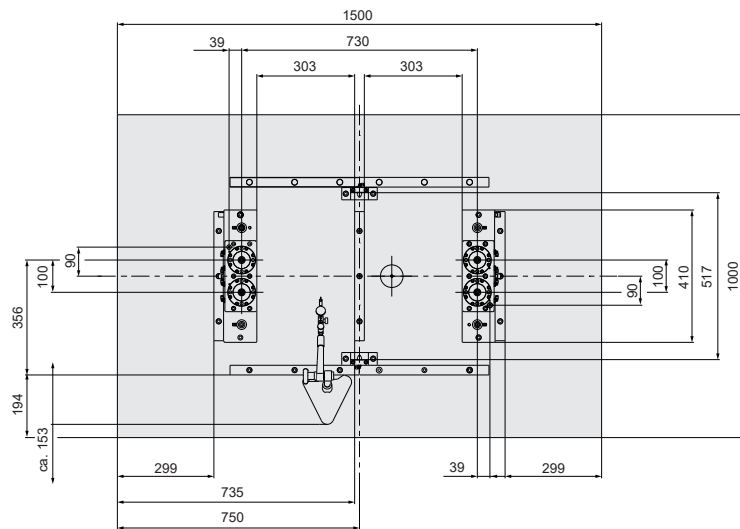
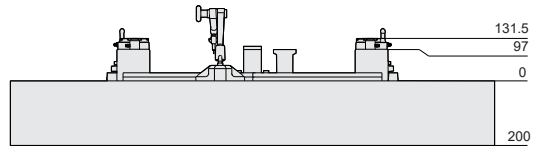

Frame tooling accessories

Set of clamping screws & brackets, C 860 200

Set of M8 screws & set screws in various lengths. Brackets to clamping bars for clamping of plates and parts thinner than 15 mm.



Pneumatic control unit, DelphinShort, C 254 960

Control unit for individual DelphinShort chucks and WEDM frames with manual operation.

- Including 10 m tube $\varnothing 6$ mm and 3 fittings.



DelphinShort Twin levelling adapter, C 952 900

For mounting SuperVice, a holder or a fixture in the DelphinShort WEDM Frames machine equipment.

Note: All holders including HP can be mounted.

- Adjustable in three axes
- Adapted for automatic changing
- Prepared for Gripper 26937-00
- Code carrier fixture included
- Recommended maximum load 15 kg.

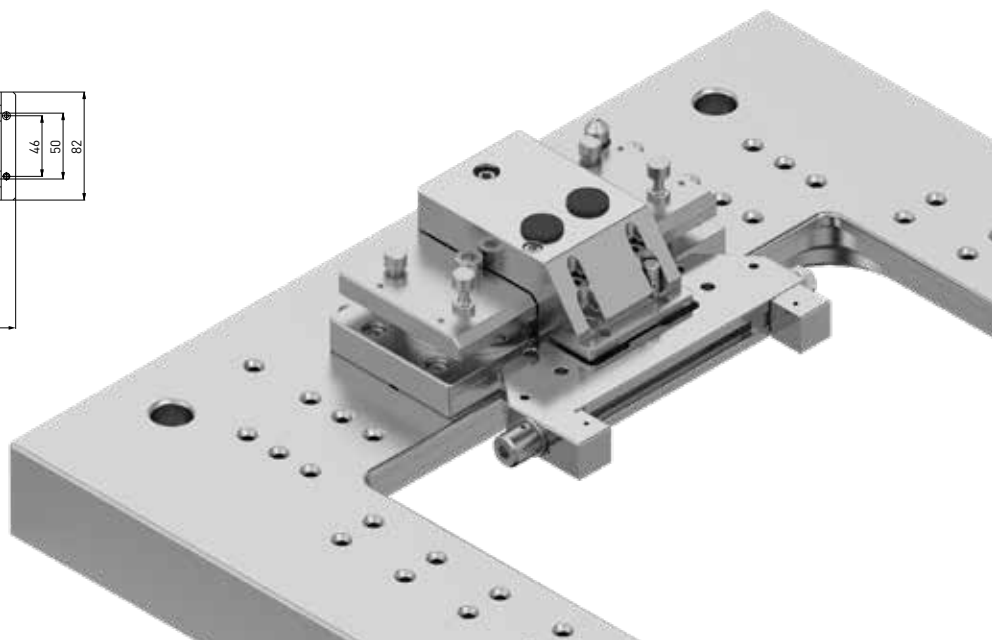
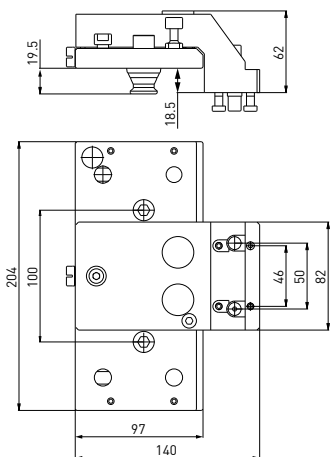

Why Delphin?

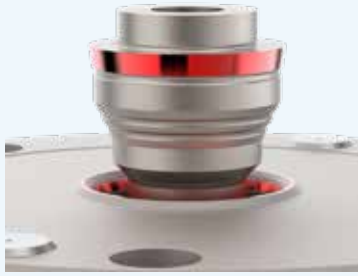

+ Highest repeatability.

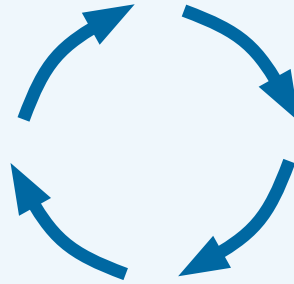

+ Highest process reliability.

Quality

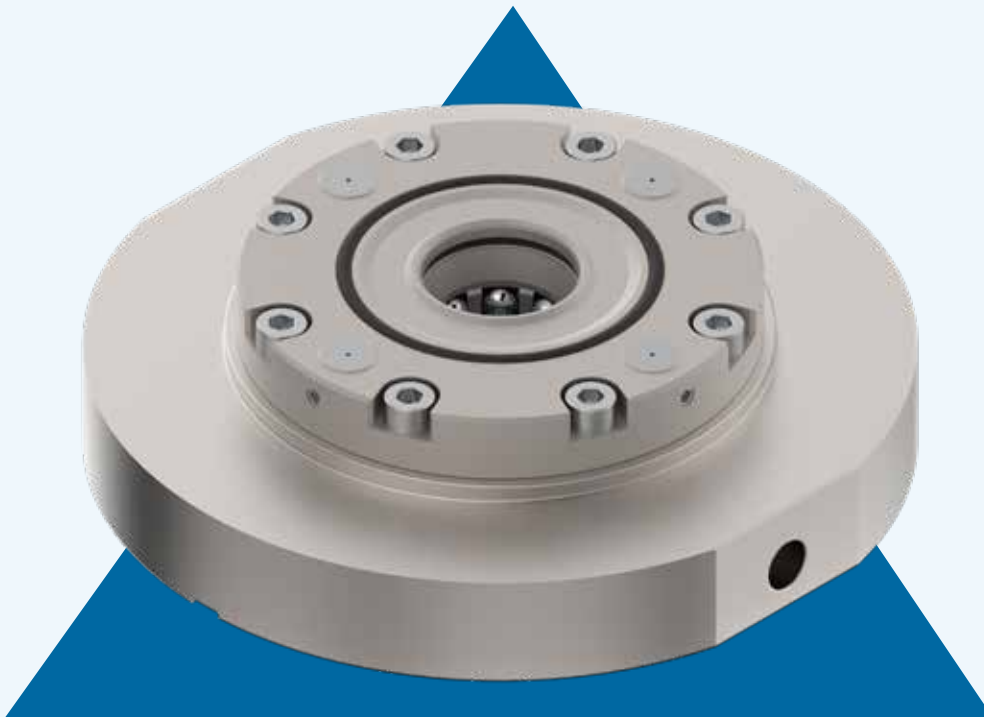

Flexibility

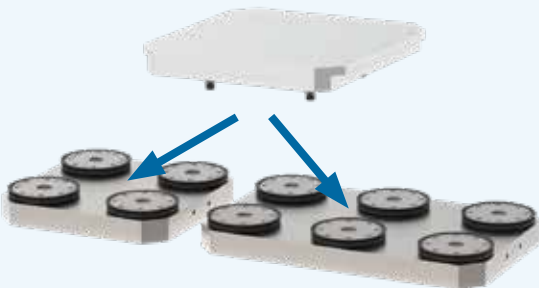

- + The Delphin clamping system is modular and adapts to your machine
- + Standardized interface for all machines.

Productivity



- + Fastest possible pallet, device and workpiece change
- + Less set-up time
- + Unmanned work with Delphin automation.

DelphinShort chuck

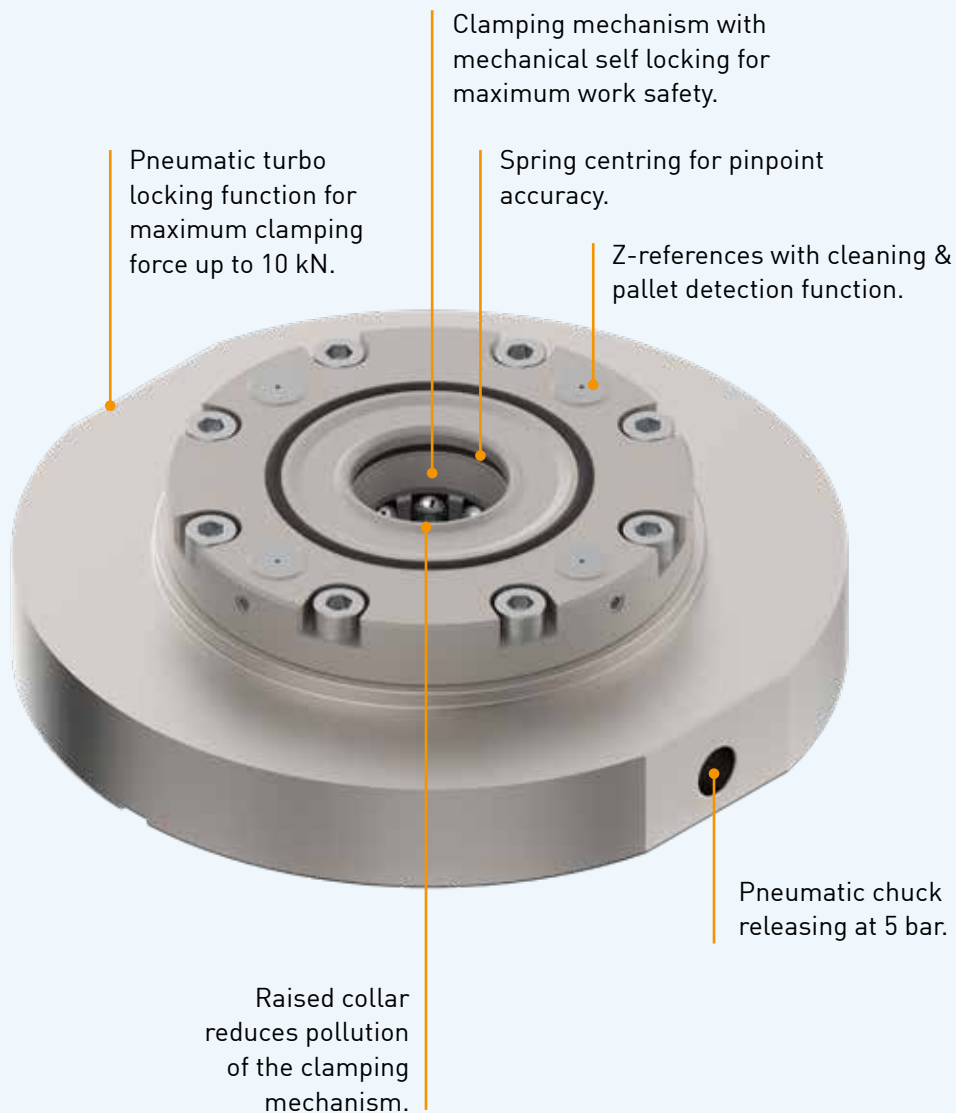

Key Facts

- + Very compact design: outer diameter 86 mm, low height
- + Stainless steel - mainly to be used in WEDM or in EDM, turning, grinding and milling with limited space
- + High clamping force (up to 10 kN with turbo locking)
- + Pneumatic opening at 5 bar
- + A special designed DelphinShort drawbar is needed. The DelphinShort drawbars are not compatible with the standard Delphin drawbars.

DelphinShort chuck



Cleaning of Z-support

Perfectly balanced Z-support surface for the best possible cleanliness against dirt and for detection.

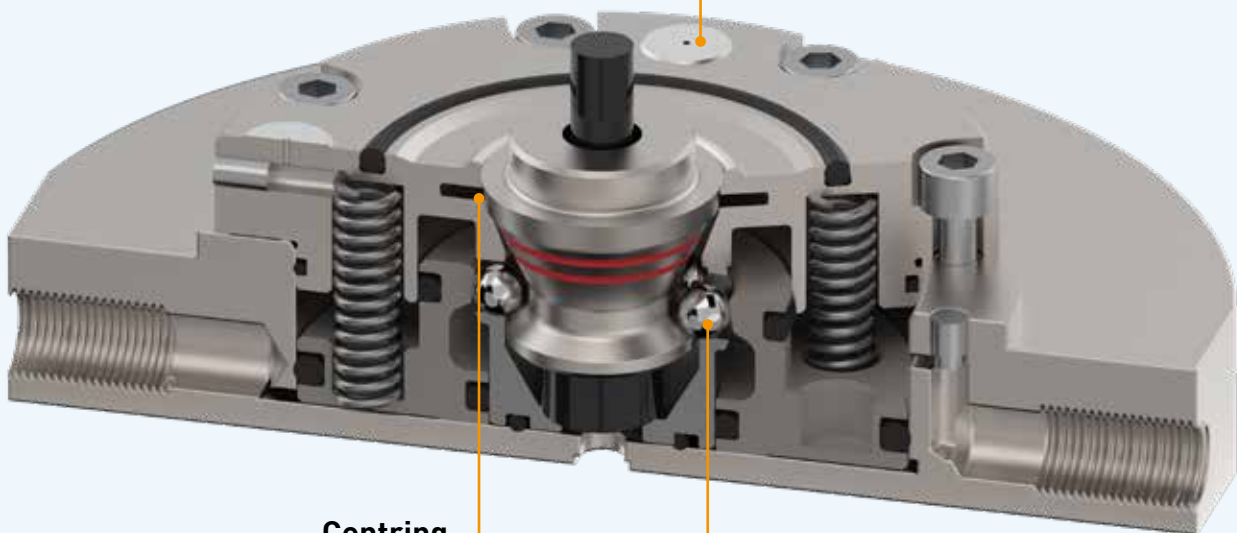

Centring

Conical spring centring for absolutely zero play between drawbar and chuck. It results the highest repeatability, excellent rigidity and less vibration.



Dirt insensitive

Floating ball cage allows a larger angular deviation between pallet and chuck during loading and unloading. In addition the design is dirt insensitive.



DelphinShort chuck

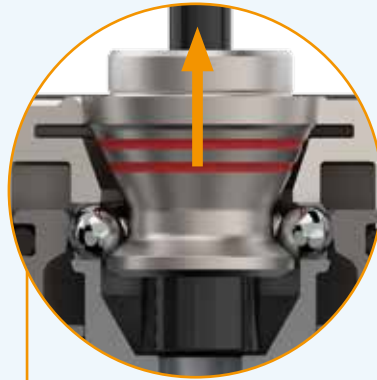

Required air pressure

Many clamping systems need compressed air with minimum 6 bar. The DelphinShort chuck requires only 5 bar air pressure to open the chuck and release the drawbar. This saves money and increases the process security.

Holding force

The holding force indicates the maximum permissible pull out force. This force determines the safety until a pallet is pulled out of the chuck. DelphinShort chucks have a minimum holding force of 20 kN.

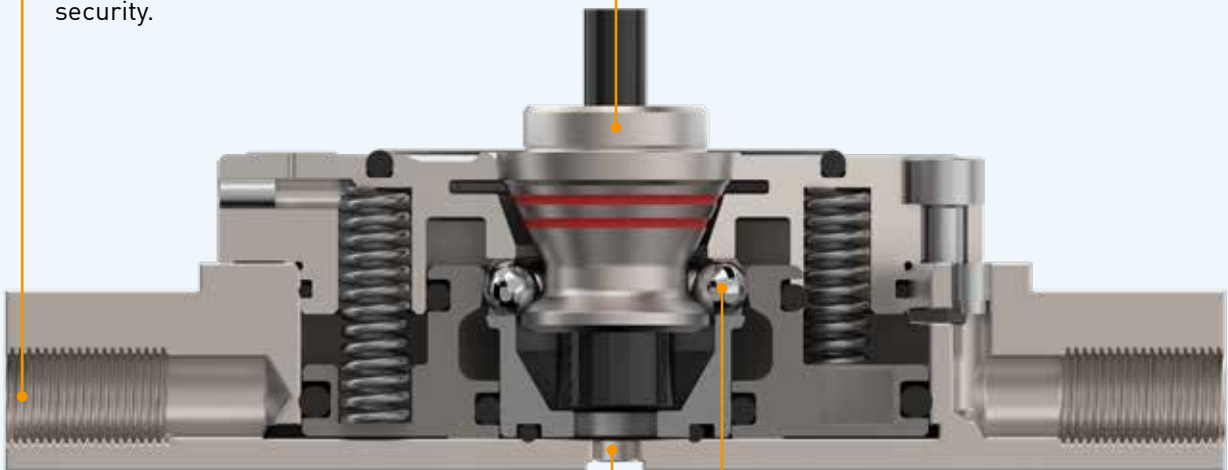

Drain hole

When unloading a pallet, it can happen that dirt and water pass into the clamping system. The DelphinShort system has a drain hole. Therefore, dirt and water flush out and the chuck keeps the functionality.

Clamping force / pull in force

The "clamping force" or "pull in force" indicates how much the drawbar is pulled into the system. Together with other features like the centring, it is responsible for the stability and rigidity of a system.

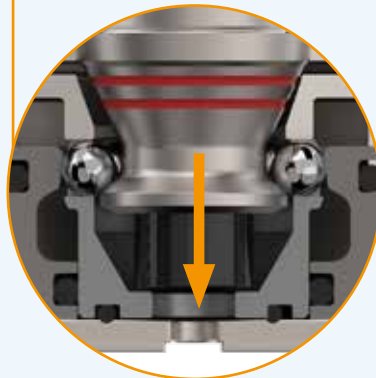

DelphinShort – for automation and manual applications

Technical data

- + Clamping force with Turbo 6 bar: 10 kN
- + Clamping force without Turbo : 5 kN
- + Holding forces:
 - Drawbar screw M8 A4-80: 20 kN
 - Drawbar screw M8 12.9: 35 kN
- + Air pressure open: 5–10 bar
- + Repeatability: within 0.003 mm
- + Material: hardened stainless steel.

Suitable for:



Built-in chuck, DelphinShort, C 225 000

For simple installation in the machine table or in a baseplate.

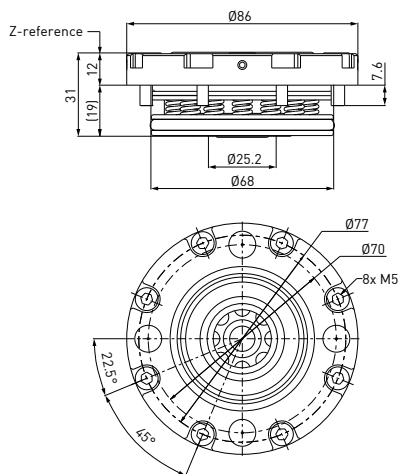

Built-up chuck, DelphinShort, WEDM flange, C 225 300

For simple installation on WEDM machine tableframe.

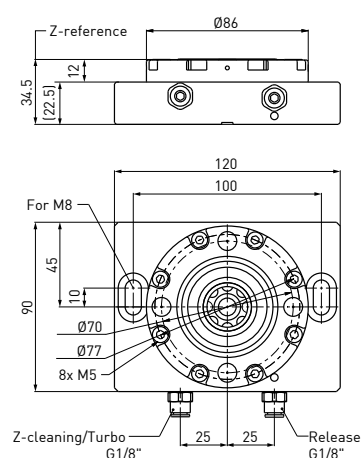

Built-up chuck, DelphinShort, C 225 310

For direct installation on a machine table. Mounting holes to be drilled at installation.

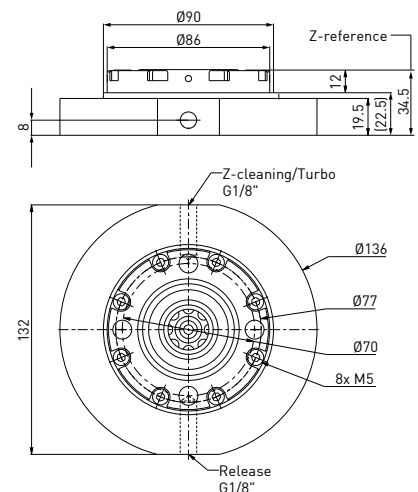

Delphin Drawbars

Function of the drawbars

Drawbars are mounted directly into a workpiece, pallet or fixture. There are three different types of drawbars. One defines the zero point and centers thus in 2 axes. The second drawbar is centring in one axis. All other drawbars have no centring, only clamping function.

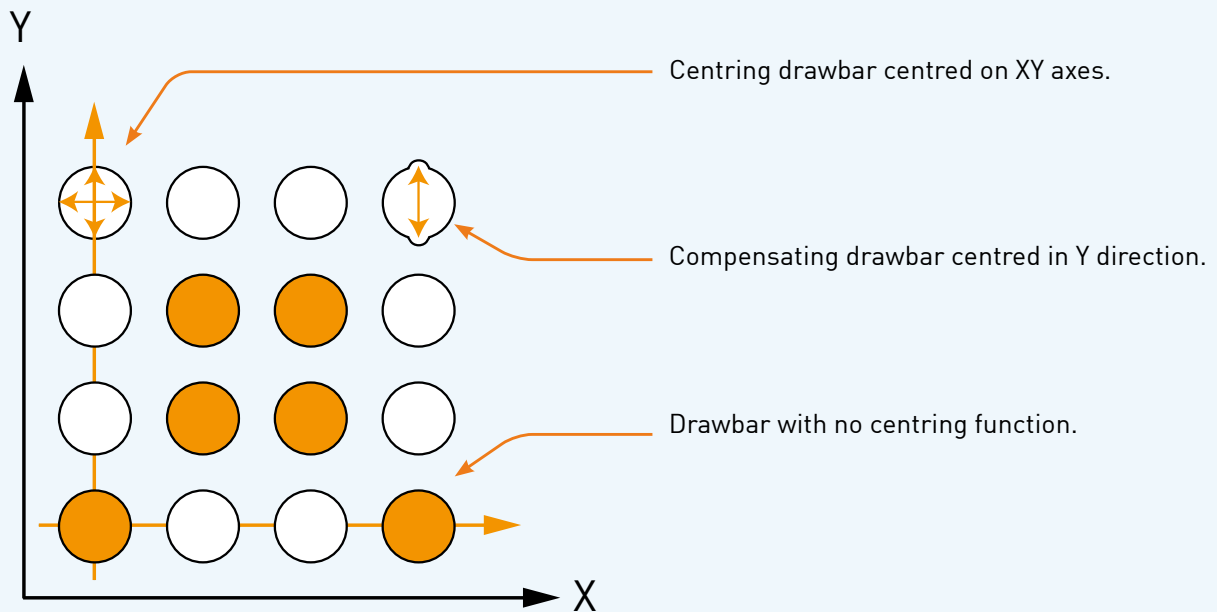

For centring in 2 axes
= zero point.



For centring in 1 axis
= angle definition.



No centring
= only clamping.



DelphinShort Drawbars

DelphinShort Drawbar, centring in 2 axes, C 226 000

Fixed in WEDM frame or pallet

- Material: stainless steel, hardened and ground
- Dimensions, screwed in: $\varnothing 26 \times 27.5$ mm.



DelphinShort Drawbar, centring in 1 axis, C 226 100

Fixed in WEDM frame or pallet

- Material: stainless steel, hardened and ground
- Dimensions, screwed in: $\varnothing 26 \times 27.5$ mm.



DelphinShort Drawbar – without centring, C 226 200

Fixed in WEDM frame or pallet

- Material: stainless steel, hardened and ground
- Dimensions, screwed in: $\varnothing 26 \times 27.5$ mm.



Function of the Delphin drawbars

- centring on 2 axes
- centring on 1 axis
- without centring

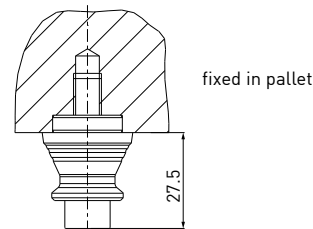

Drawbar positions in WEDM Frames

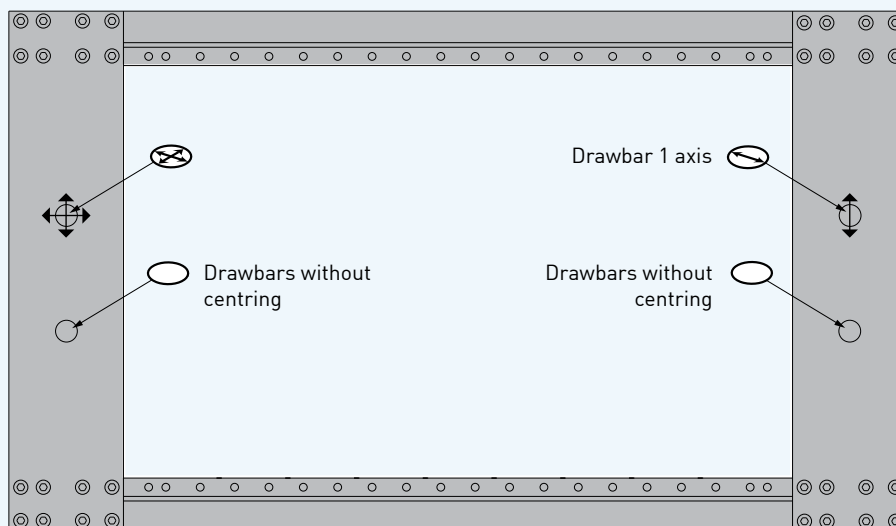

DelphinShort Accessories

DelphinShort Reference mandrel, C 226 310

Alignment aid for chuck installation.

- Material: steel stainless, hardened and ground
- Drawbar C 226 000 included
- Diameter D = 83 mm.

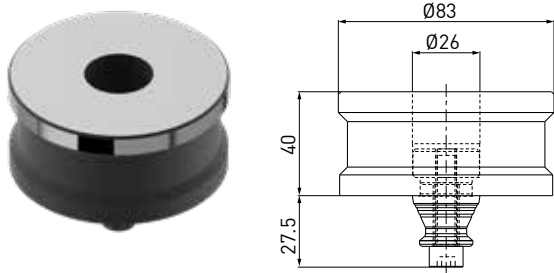

DelphinShort protective pallet, C 226 320

Chip and air pressure (turbo locking) protection for DelphinShort chuck.

- Fits also for chucks with sealing ring
- Includes drawbar C 226 000
- Diameter D = 104 mm.



DelphinShort protective drawbar, C 226 300

Chip protection for DelphinShort chucks, seals centre bore, Z-support of chuck remains usable.

- Material: plastic
- Dimensions: Ø26x21 mm
- M8 for dismounting.

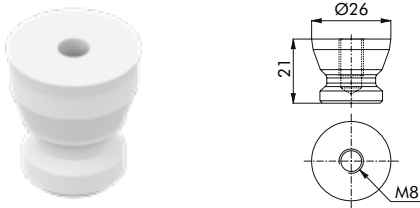

DelphinShort chuck sealing ring, C 226 390

To be used on built-in chucks C 225 310.
Not recommended on C 225 300.



Pneumatic control unit, DelphinShort, C 254 960

Control unit for individual DelphinShort chucks and WEDM frames with manual operation.

- Including 10 m tube Ø6 mm and 3 fittings.



Spare parts, DelphinShort, S 225 005

For DelphinShort chucks. Includes O-rings, compressions springs, balls, screws and assembly tool.

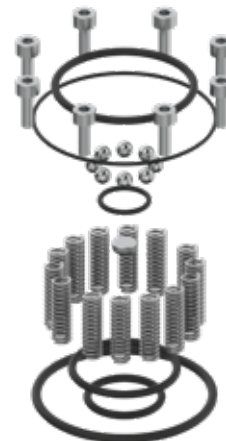

Contents

C 225 000.....	21	C 917 140.....	8, 9, 12, 13	C 952 900.....	16
C 225 300.....	21	C 917 150.....	10, 11, 14, 15	C 953 000.....	13
C 225 310.....	21	C 917 160.....	10, 11, 14, 15	C 953 050.....	14, 15
C 254 960.....	8, 12, 14, 16, 24	C 917 320.....	13	C 953 100.....	8, 9, 12, 13
C 226 000.....	23	C 917 330.....	14, 15	C 953 140.....	9
C 226 300.....	24	C 917 350.....	13	C 953 150.....	8, 12
C 226 310.....	24	C 917 360.....	14, 15	C 953 180.....	8, 9, 12, 13
C 226 320.....	24	C 917 430.....	14, 15	C 953 200.....	14, 15
C 226 390.....	24	C 917 460.....	14, 15	C 953 240.....	10, 11, 14, 15
C 860 200.....	8, 10, 12, 14	C 952 140.....	12, 13, 14, 15	C 953 250.....	10, 14
C 917 020.....	13	C 952 240.....	8	C 953 280.....	10, 11, 14, 15
C 917 030.....	14, 15	C 952 280.....	10	S 225 005.....	24
C 917 050.....	13	C 952 300.....	15	V 000 019.....	8, 9, 12, 13, 14
C 917 060.....	14, 15	C 952 350.....	14	V 000 0xx.....	10, 11, 14, 15
C 917 130.....	8, 9, 12, 13	C 952 380.....	14		

A wide range of Tooling and Automation products from a single source



Tooling Catalogues

- + Tooling – for electrode manufacturing and EDMing
- + Tooling – for wire EDMing
- + Tooling – for Parts production
- + Tooling, Delphin modular Clamping System



Automation Catalogues

- + WorkPal 1
- + WorkPartner 1+
- + Fanuc, six-axis robot
- + Software portfolio

For your own copy please contact your System 3R representative.

Optimize the uptime of your equipment with our Customer Services

System 3R's Customer Services is uniquely positioned to help you maximize the availability, value, precision and productivity of your System 3R equipment. Our cost-effective, customer-centric and expert services put your success at the center, ramp up your productivity and ensure predictable, uninterrupted uptime. System 3R's service engineers are your expert partners for a wide range of success-triggering services.

www.system3r.com.

